

REDSAN mini-Pro

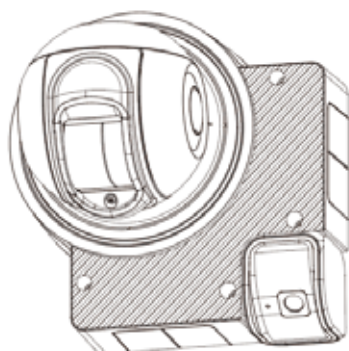

RLS-2020V

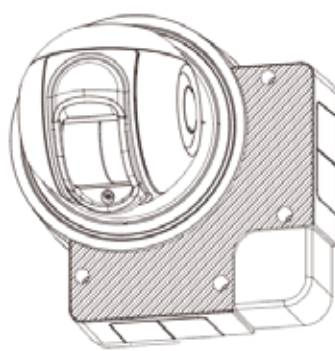

RLS-2020A

Laser Scan Detector

Setting guide (Ver. 1.1.x)

Support browser: Chrome
(running on Windows 10 or later, Mac, Android)

Table of contents

<ul style="list-style-type: none"> 1. Initial configuration 2 1-1. Configure root password 2 1-2. Sign in 2 1-3. Locale information ** 3 1-4. Configure IP address 3 1-5. Select power line frequency 4 1-6. Adjust the detection area 5 1-7. Detection 7 2. Display 10 2-1. Home view 10 2-2. Status display 11 2-3. Setting display 12 3. ONVIF settings 13 3-1. To use ONVIF 13 3-2. ONVIF menu on Profile 1 and 2 14 3-3. ONVIF menu on Advanced settings 15 4. Settings 16 4-1. Easy setup ** 16 4-2. Detection range 18 4-3. Detection profile 1 20 4-3-1. Detection area 20 4-3-2. Masking/ Allocating 22 4-3-3. Detection 24 4-3-4. Detection advanced 25 4-3-5. Dynamic event filtering 27 4-3-6. Output terminals 28 4-3-7. ONVIF digital inputs 28 4-3-8. ONVIF motion alarm 29 4-3-9. HTTP notice 29 4-3-10. Detection profile copy 30 4-4. Detection profile 2 30 4-5. Event code 31 4-6. View 32 4-6-1. Laser 32 4-6-2. Video 33 4-6-3. Map 34 4-6-4. Menu 35 	<ul style="list-style-type: none"> 4-7. Date and times 36 4-8. Network 36 4-8-1. TCP/IP Basic 36 4-8-2. TCP/IP Advanced 37 4-8-3. SNMP 37 4-8-4. RS-485 38 4-9. Maintenance 38 4-9-1. System 38 4-9-2. Logs 39 4-9-3. Import/ Export 39 4-10. Information 40 4-10-1. Product information 40 4-10-2. Installation information 40 5. Advanced settings 41 5-1. Menu view 41 5-2. Input 42 5-2-1. Input terminal 42 5-2-2. ONVIF Relay output 42 5-3. Laser settings 43 5-4. Camera settings * 44 5-4-1. Image adjustment 44 5-4-2. Privacy mask 45 5-4-3. Day/Night 46 5-4-4. Miscellaneous 46 5-5. ONVIF media profile 47 5-5-1. H.264 Encoding 47 5-5-2. JPEG Encoding 47 5-6. Event log 48 5-6-1. Record 48 5-6-2. Play 49 5-7. Security 50 5-7-1. User Management 50 5-7-2. ONVIF User Management 51 5-7-3. Certificates 52 5-7-4. HTTPS 53 5-7-5. IEEE 802.1X 53
--	---

** = Ver. 1.1 or later

* = RLS-2020V only

1. Initial configuration

Configure root password

The password for the administrator "root" must be changed before the product can be used.

Password:

Confirm password:

The password must be 8 characters or more, and should be set with a combination of 2 or more types of numbers, uppercase letters, lowercase letters, and symbols.

Available symbols: ! " # \$ % & ' () * + , - . / : ; < = > ? @ [] ^ _ ` { | } ~ space

OK

1-1. Configure root password

Available:

Alphabets [A to Z.]

Numbers [0 to 9]

Symbols

[! " # \$ % & ' () * + , - . / : ; < = > ?

@ [] ^ _ ` { | } ~ space]

Root password

"Root password" is used for the authorization of the administrator.

It must be configured before starting the settings through this software.

1.1.x (xxxx/xx/xx)

Sign in

http://192.168.0.126

Your connection to this site is not private.

User name

Password

Sign in Cancel

1-2. Sign in

User name: root

Password: As you created in the previous section

The screenshot shows the 'Please configure the locale information.' screen. It features three dropdown menus: 'Language' set to 'English', 'Time zone' set to 'GMT Dublin, Lisbon, London, Reykjavik', and 'Unit' set to 'Metric'. A 'Next' button is located at the bottom left.

** = Ver.1.1 or later

1-3. Locale information *

Select language, time zone and unit to be used in this software.

Default: English, GMT and metric

The screenshot shows the 'Please configure IP address.' screen. It features four input fields: 'Configuration' (Static), 'IP address' (192.168.0.126), 'Subnet mask' (255.255.255.0), and 'Default gateway' (192.168.0.1). At the bottom, there are two buttons: 'Save & Reboot' and 'Next'. Red arrows point from the 'Next' button to the text below and from the 'Save & Reboot' button to the text below.

1-4. Configure IP address

Configure the IP address of the REDSCAN mini-Pro device.

Configuration: [static, DHCP]

IP address: **default 192.168.0.126**

Subnet mask: **default 255.255.255.0**

Default gateway: **default 192.168.0.1**

Next: Go to next item **without** any changes.

Save & Reboot: Save the changes, and reboot automatically.

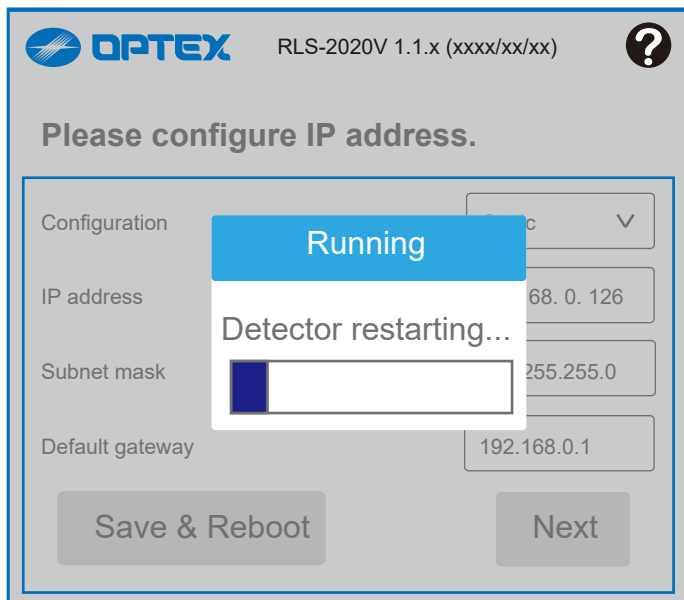

The screenshot shows the 'Please configure IP address.' screen. It includes fields for IP address (192.168.0.126), Subnet mask (255.255.0), and Default gateway (192.168.0.1). A blue dialog box with the text 'Running' and 'Detector restarting...' is overlaid on the configuration fields. Below the fields are 'Save & Reboot' and 'Next' buttons.

Wait for detector to reboot

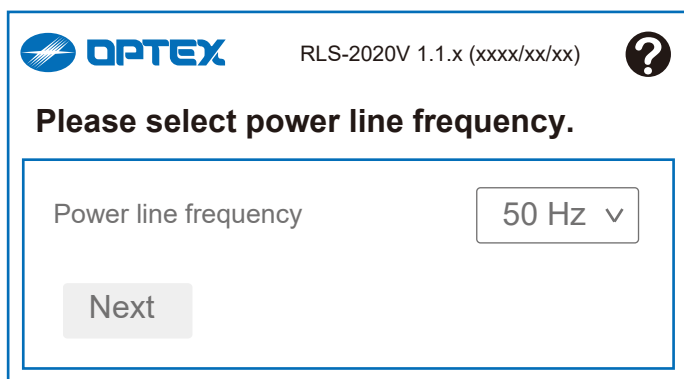

The screenshot shows the 'Please select power line frequency.' screen. It features a dropdown menu for 'Power line frequency' set to '50 Hz' and a 'Next' button.

1-5. Select power line frequency

Select power line frequency [50 Hz, 60 Hz]

1-6. Adjust the detection area

Adjust the detection area, according to the installation instructions.

«Normal mode»

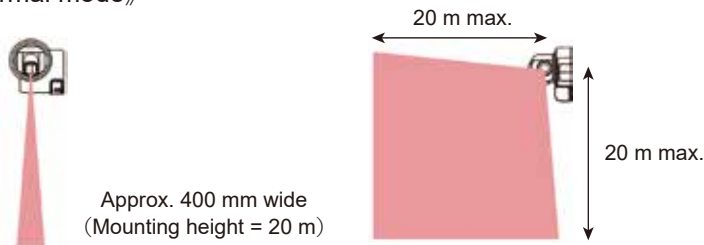

«Area expansion mode»

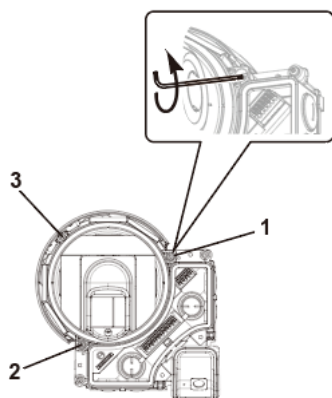
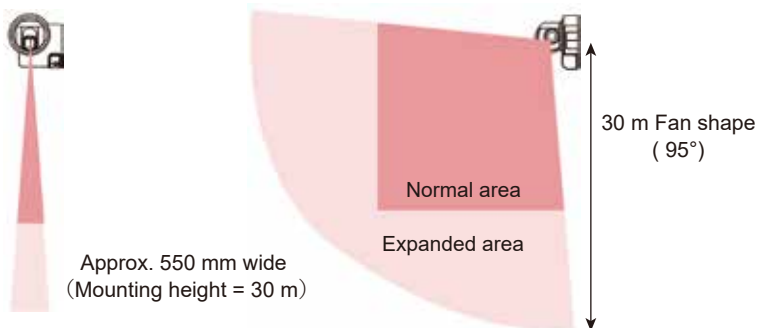

RLS-2020V



RLS-2020A

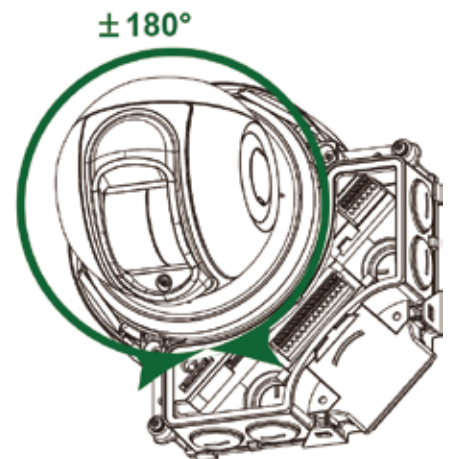

- ✓ Just loosen.
- ⊘ Do not remove.

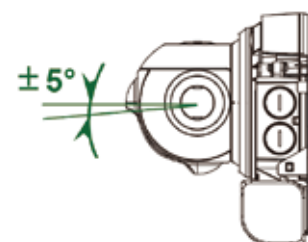
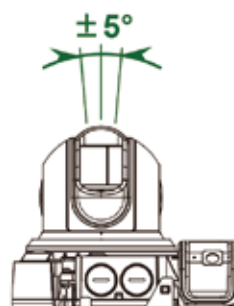

Angle Adjustment

A fine angle adjustment with LAC-1

Adjust the position of laser path with LAC-1 which provides LED and sound when it receives infrared beams to secure required detection area.



< HINTS >

3 LEDs indicate detection area sensitivity independently to locate high sensitive area precisely.

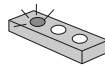

If one of 3 LEDs is blinking quickly, it is detecting the laser but the others are not detecting.

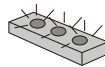

If all 3 LEDs are blinking quickly, all are detecting the laser.

Example 1: Confirmation of both ends of the detection area

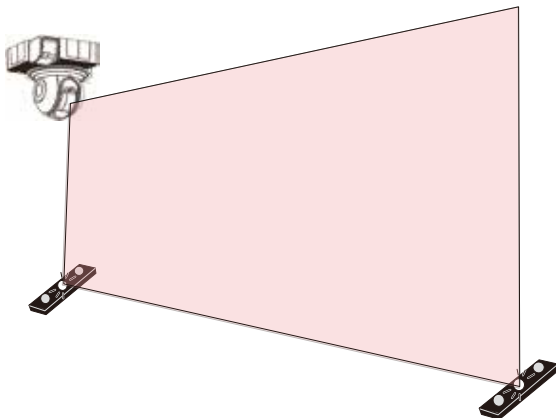

Example 2: Confirmation within the detection area

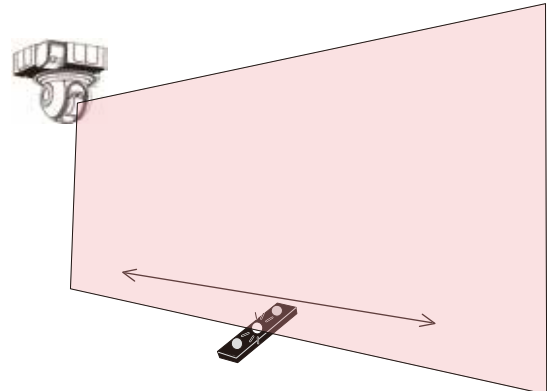

Example 3: Confirmation of each area direction

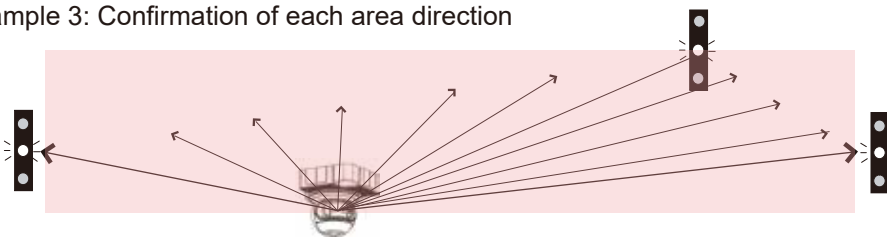

1. Instruct a person hold the LAC-1 and stand at either side edge of required protection area.
2. The person should hold LAC-1 in front of their body between shoulder and hip line.
3. Adjust the position of laser beams by moving the main unit slowly so that LAC-1 blinks.

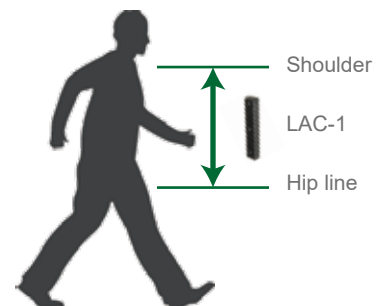

1-7. Detection

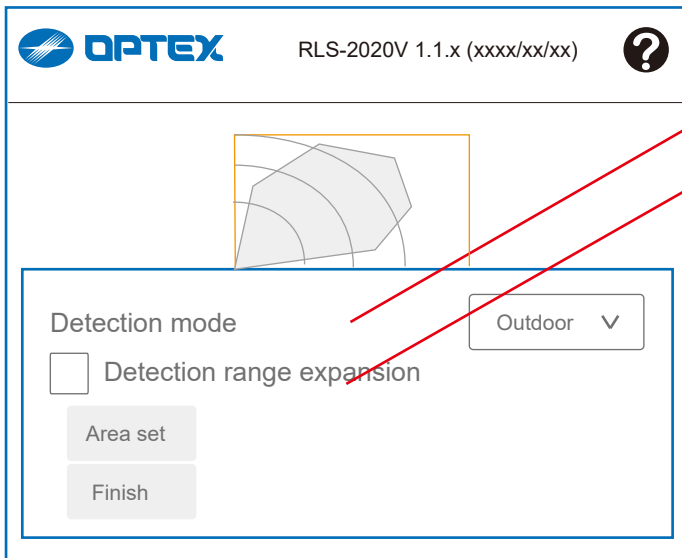

Detection mode: [Outdoor, Indoor]

Detection range expansion:

-> **See the column below for details**

Area set

Finish

Detection mode

Outdoor Mode:

This option can be selected for general outdoor applications. In this mode, the special algorithm works to reduce false alarms caused by weather conditions (e.g. rain, snow or fog). In order to reduce false alarms under harsh environment, the Environmental Resistance function is available.

Indoor Mode:

For general indoor applications. In this mode, Environmental Resistance and DQ Output are disabled.

Detection Range Expansion Mode

The detection range of REDSCAN mini-Pro can be extended to 30 m and become a fan shape of arc 95°

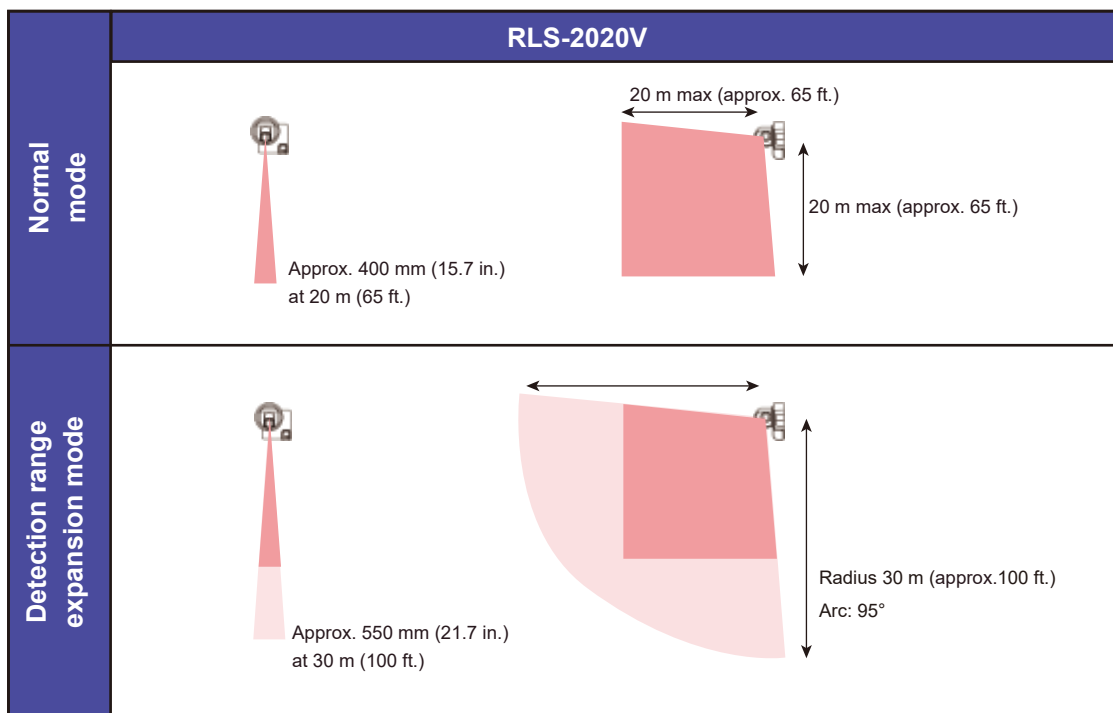

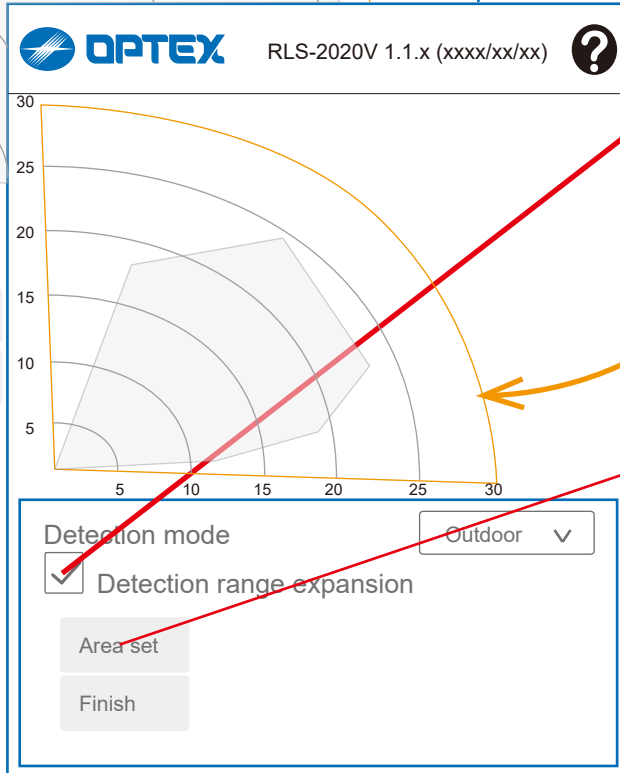
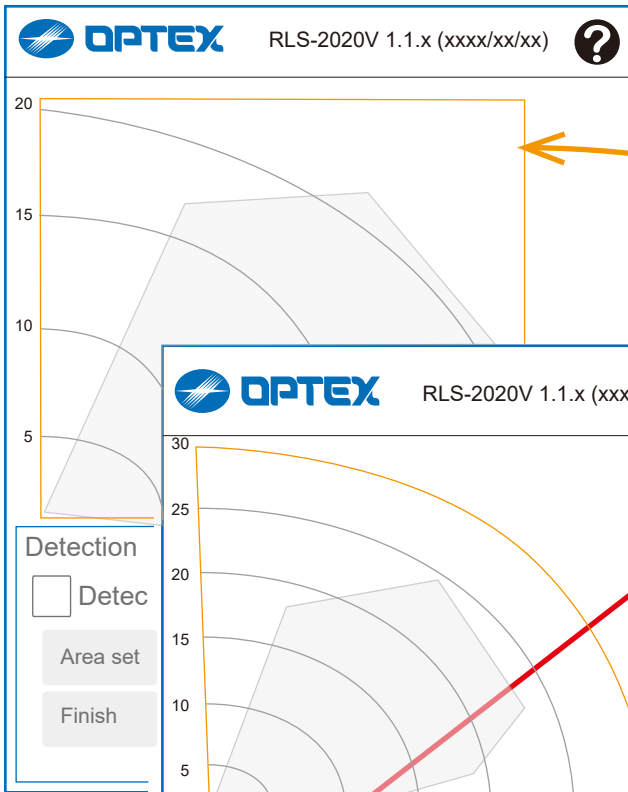

- Detection range expansion
- Detection range expansion

Area set

Start the area scanning and then setting.
A pop-up window opens to confirm Area Set.

Area setting

“Area setting” enables learning of the limits of the detection area. The background information is base for decreasing false alarm.

*** Ensure the detection area is free from obstructions during area set**

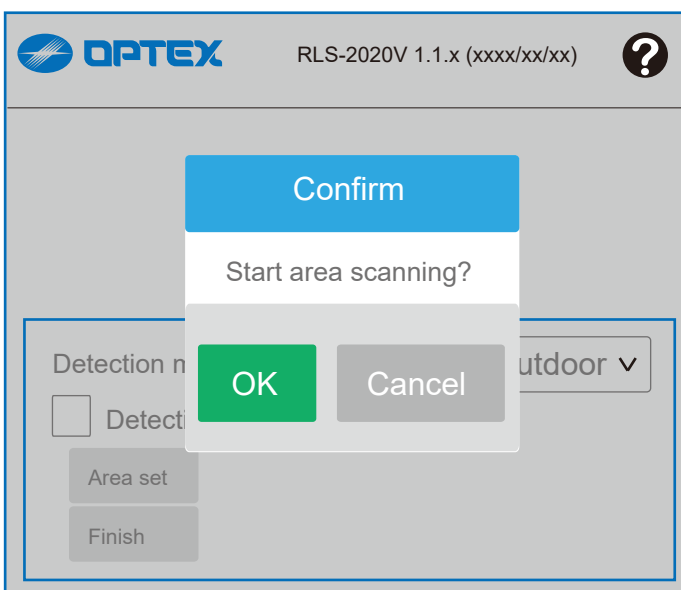

Area scanning start

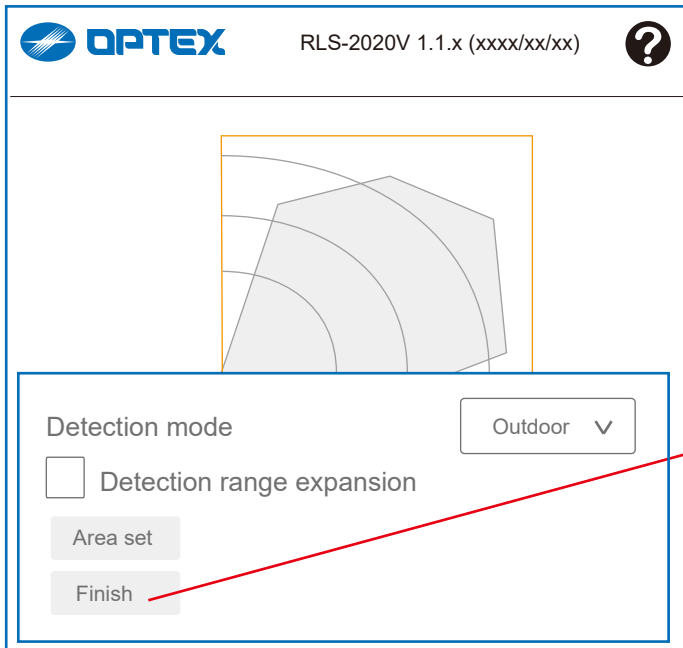

The last screen of the "1. Initial configuration" .
Click on "Finish" to complete procedure.

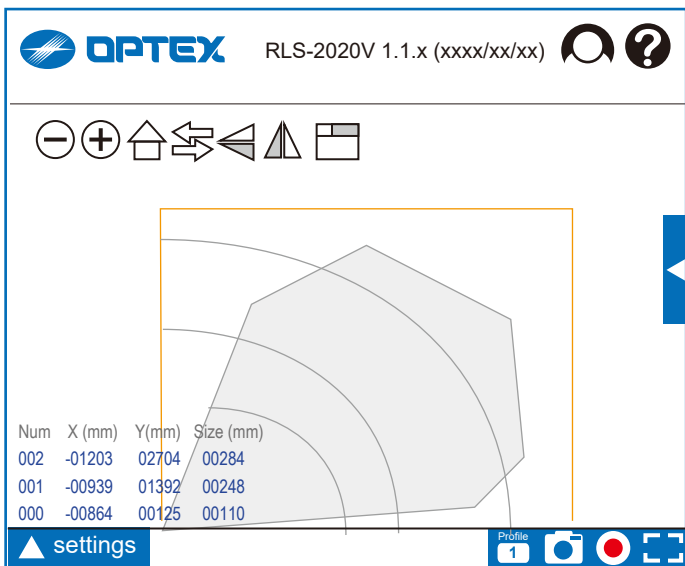

The "Home view" screen appears after the
"1. Initial configuration" process has been completed.

2. Display

2-1. Home view

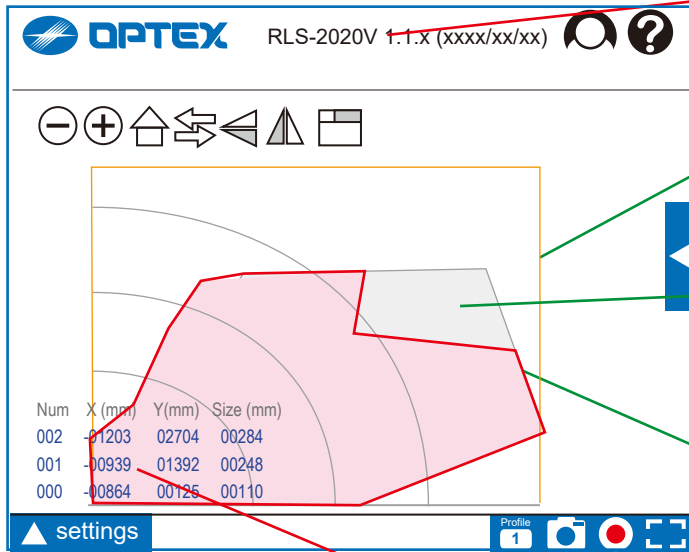

RLS-2020V 1.1.x (xxxx/xx/xx)

Location of the software version and the date of the last update.

Detection range

Limits of the detection area.

Sensing area

The location displayed in gray is the area actually detected by the laser sensor.

Detection area

You can create the detection area by adjusting the sensing area, such as cutting, masking or allocating so on, within the detection range.

Indicator of the intrusion number, location and size

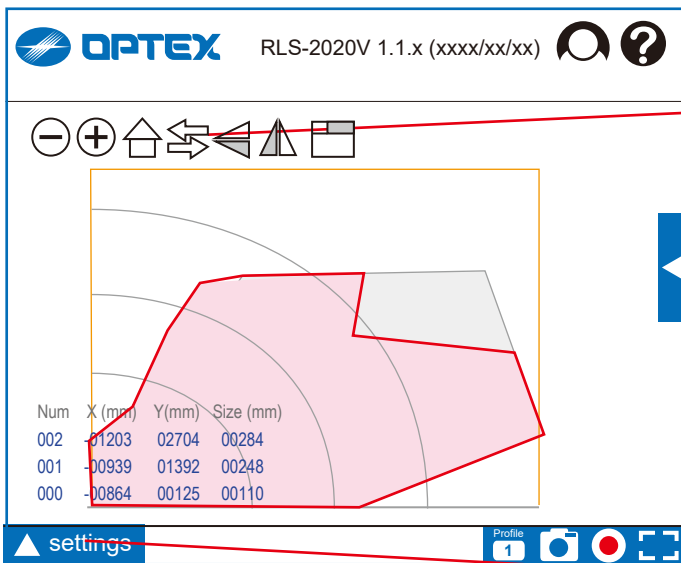

Zoom out

Zoom in

Back to the home position

Switching between the home view and camera view



Flip vertical

Flip horizontal

Open additional window for either the Home view or the camera image

Open the setting window

Click to open the windows for the settings.

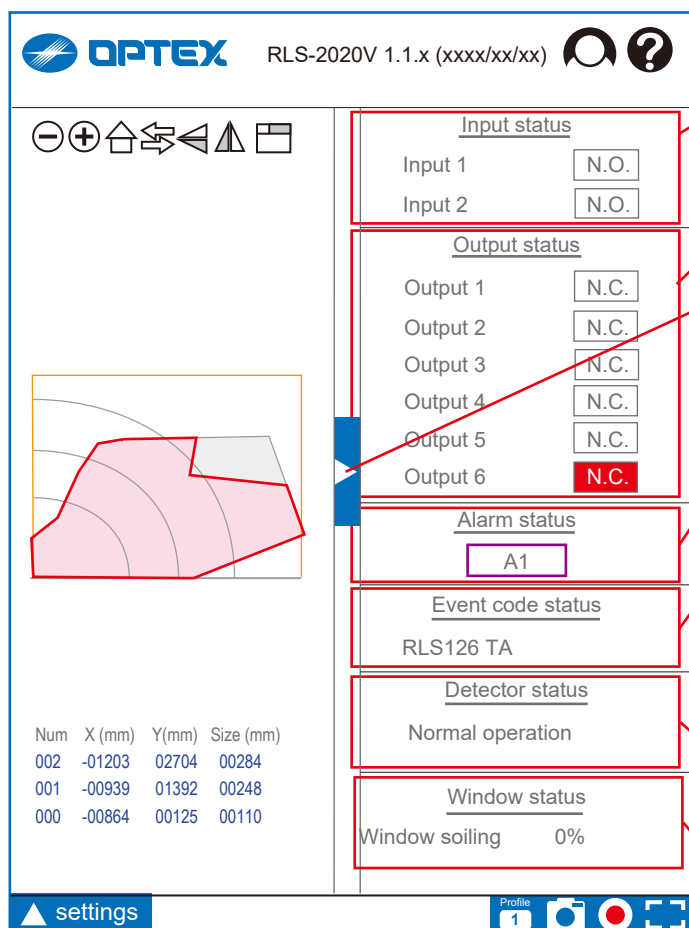
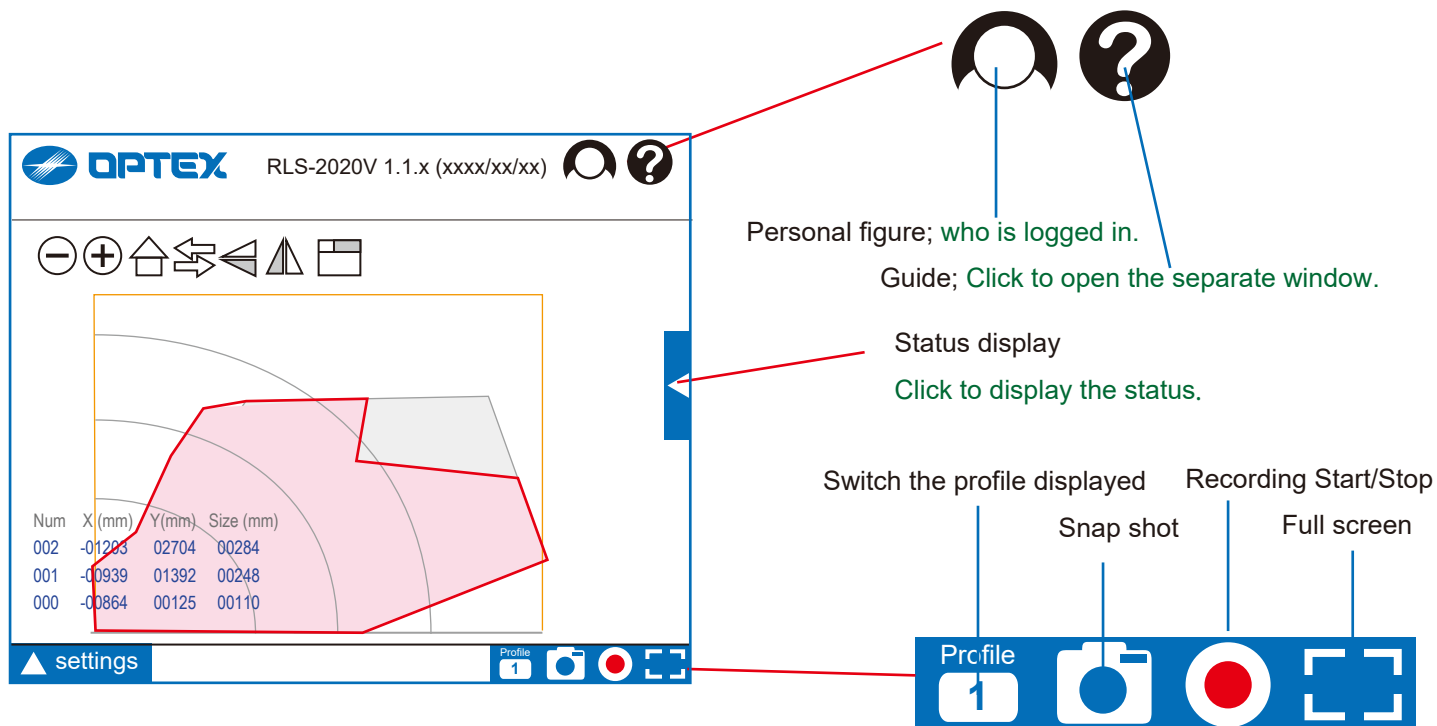

2-2. Status display

Input status [N.C., N.O.]

Current input is shown in red.

Output status [N.C., N.O.]

Current output is shown in red.

Status display

Click to slide open/close.

Alarm status

Current alarm status is shown in red.

Event code status

All the codes (**R.E.C. = REDSCAN Event Code**) that currently output are listed.

R.E.C. (REDSCAN Event Code)

- | | |
|------------------------------------|-----------------------|
| A1, A11, A12: Zone alarm | |
| AM: Anti-Masking | AR: Anti-Rotation |
| DQ: Environmental Disqualification | DM: Device Monitoring |
| MO: Master Alarm | SO: Soiling |
| TA: Tamper Output | TR: Device Trouble |

Detector status

[Normal operation, Hardware error, Over heat
Camera error, Others error]

Window status

The dirt rate of the window is displayed in %.

2-3. Setting display

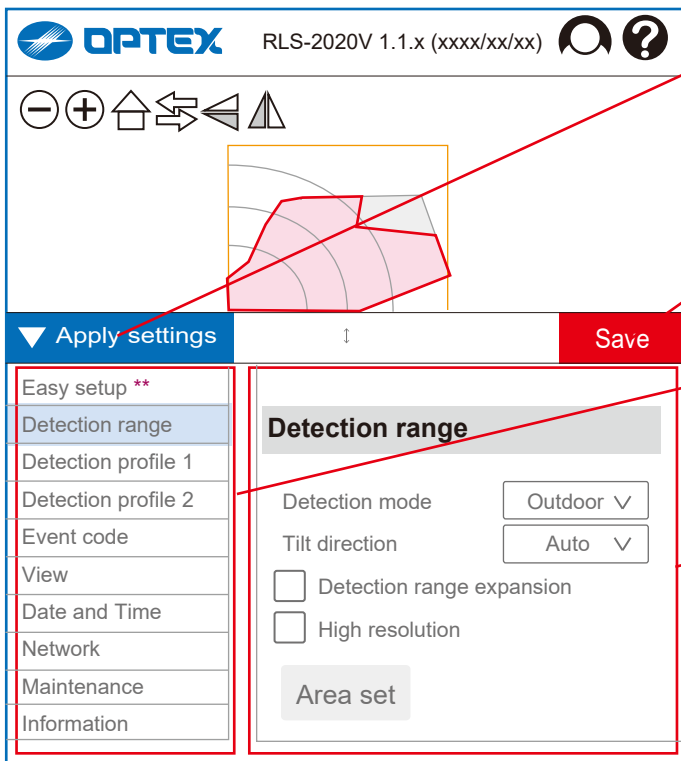

Apply settings
Click to apply changes, to close the settings window and to restart the process.

Save the settings
Click to save the set parameters.

Menu window
List the setting menu
Selected item is indicated in blue.

Setting window
Display the setting item.

** = Ver.1.1 or later

Setting display for a Smart Phone

On the setting screen for PC, menus and settings are displayed on one screen, while for smartphones, both are manually switched and displayed.

If the screen for smartphones is displayed on the PC screen, change the browser to full screen and reload.

Settings for a PC display

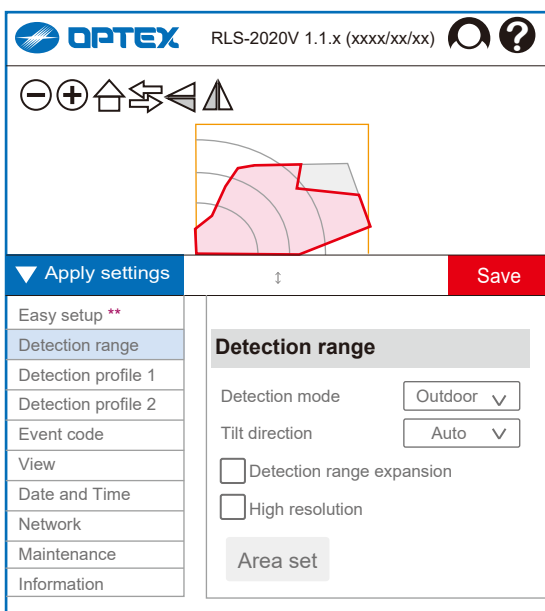

Settings for a Smart Phone

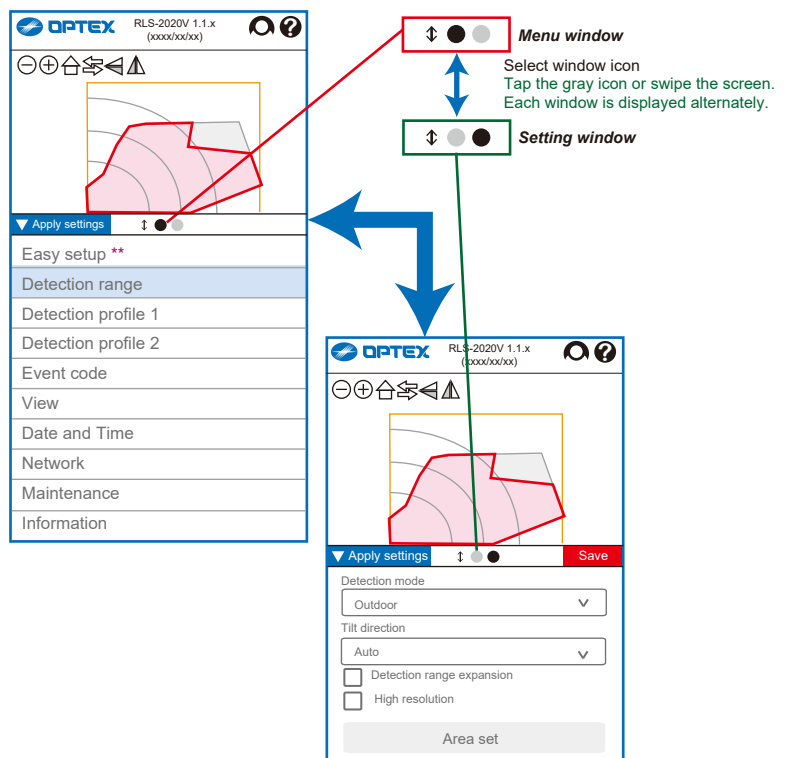

3. ONVIF settings

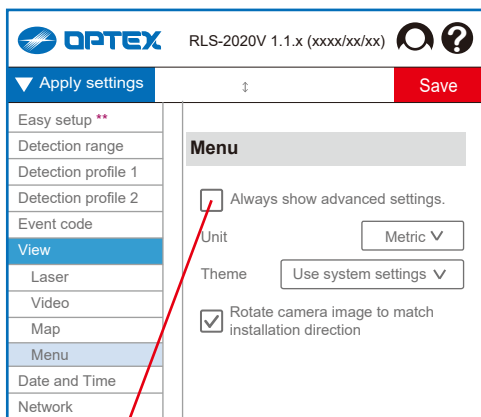

** = Ver.1.1 or later

Always show advanced settings

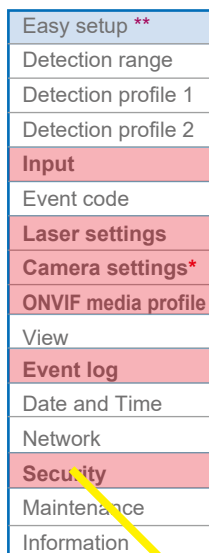
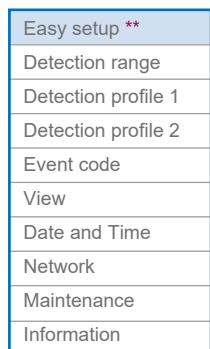

 = Advanced settings -> See section 3
 * = RLS-2020V only ** = Ver.1.1 or later

REDSKAN mini-Pro series supports ONVIF and RTSP.
 Client application can get video stream of embedded camera in REDSCAN mini-Pro series.
 Username and password are common to ONVIF and RTSP.
 Even if ONVIF is not used, create ONVIF account by the sequence below to use RTSP authentication.

ONVIF
 ONVIF is an open industry forum that provides and promotes standardized interfaces for effective interoperability of IP-based physical security products. See the site below for details. Specifications are downloadable.
<https://www.onvif.org/>
 ONVIF Device manager is popular tool in the industry. It enables accessing and testing ONVIF device. See the site below for details.
<https://sourceforge.net/projects/onvifdm/>

3-1. To use ONVIF

- [1] Select "View" then "Menu".
- [2] Click "Always show advanced settings".
- [3] Select "Security" then "ONVIF User Management"
- [4] Following items are set by default.

User name: root

User group: Administrator

Password: **As you set it as the initial value** -> Sec 1-1. Configure root password

Add or modify them, if you need.

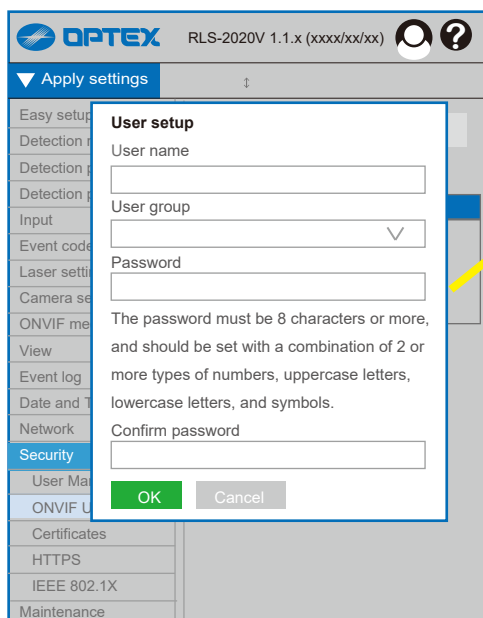
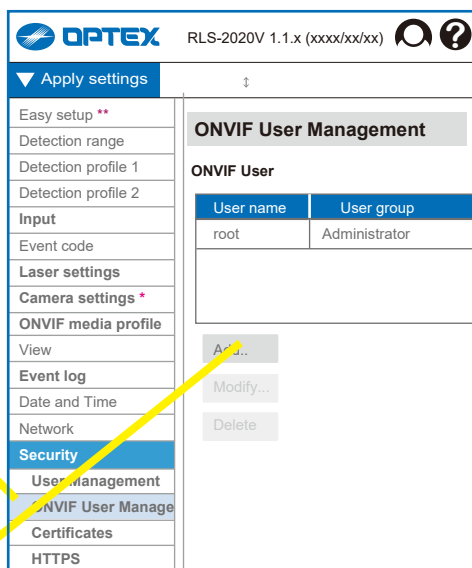

User setup

User name

User group

Select user group that is defined by ONVIF.

Password

The password must be 8 characters or more, and should be set with a combination of 2 or more types of numbers, uppercase letters, lowercase letters, and symbols.

Confirm password

OK

Cancel

3-2. ONVIF menu on Profile 1 and 2

When "Always show advanced settings" is enabled,
2 ONVIF menu items appear on each Profile 1 and 2.

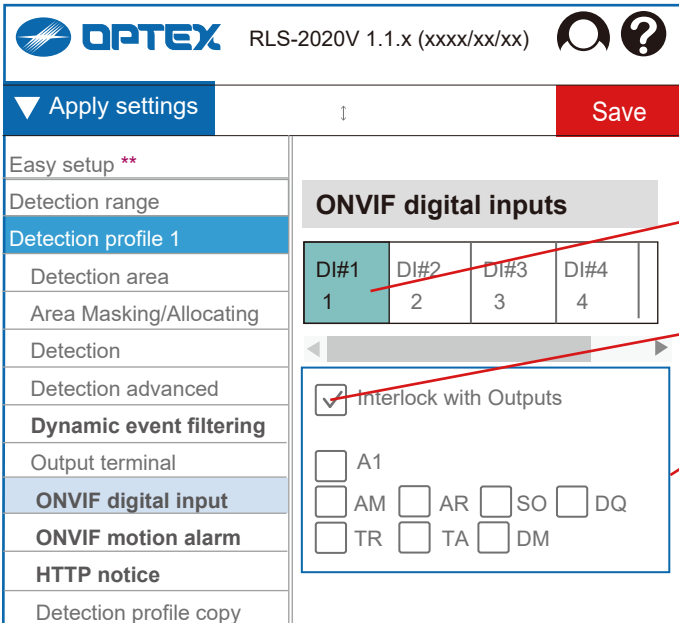

4-3-7. ONVIF digital inputs

You can set each terminal individually according to the ONVIF format.

Select the terminal for settings

[DI#1, 2, 3, 4, 5, 6]

Interlock with Outputs

Select events

[A1, A11, A12, A21, A22, B11, B12, B21, B22, AM, AR, SO, DQ, TR, TA, DM]

Respond when the selected event occurs.

The choices appear only when "Interlock with Outputs" is not selected.

(Bold letters = advanced settings)

** = Ver.1.1 or later

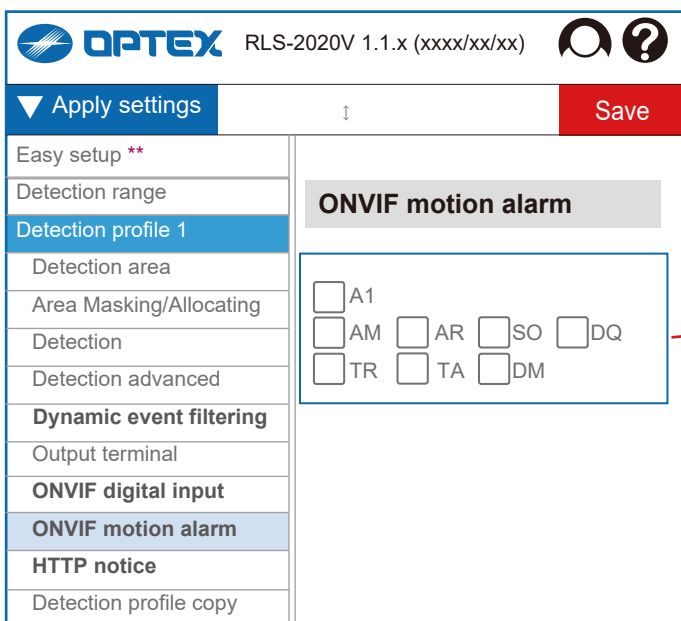

4-3-8. ONVIF motion alarm

You can set the ONVIF motion alarm responding to the select events.

Select events

[A1, A11, A12, A21, A22, B11, B12, B21, B22, AM, AR, SO, DQ, TR, TA, DM]

Respond when the selected event occurs.

R.E.C. (REDS CAN Event Code)

A1, A11, A12 B11, B12: Zone alarm

AM: Anti-Masking

AR: Anti-Rotation

DQ: Environmental Disqualification

DM: Device Monitoring

MO: Master Alarm

SO: Soiling

TA: Tamper Output

TR: Device Trouble

(Bold letters = advanced settings)

** = Ver.1.1 or later

3-3. ONVIF menu on Advanced settings

When "Always show advanced settings" is enabled,

2 ONVIF menu items also appear on ONVIF media profile.

These settings apply to video streaming over ONVIF (RTSP/RTP).

They do not apply to camera images on web browsers and camera images in event logs.

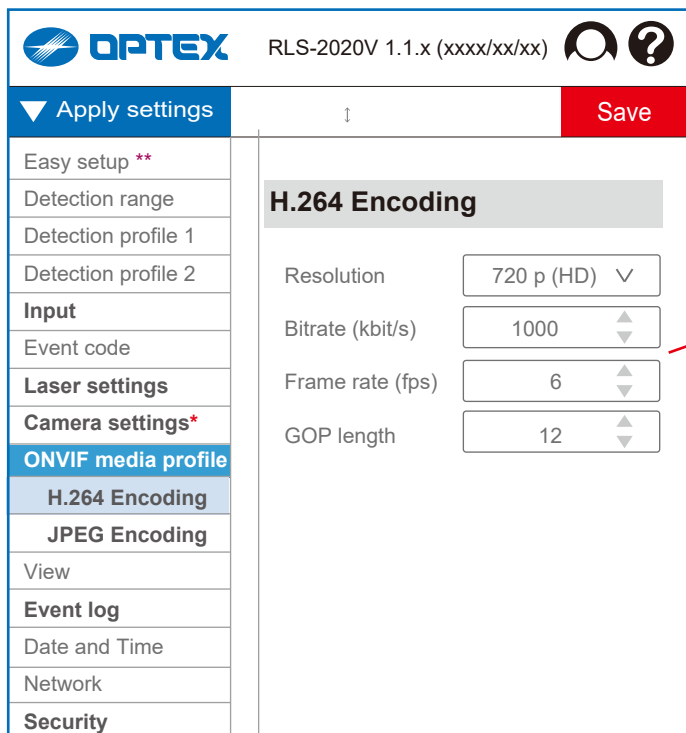

(Bold letters = advanced settings)
 .* = RLS-2020V only ** = Ver.1.1 or later

5-5. ONVIF media profile

5-5-1. H.264 Encoding

Resolution

[1080 p (FHD), 720 p (HD), 360 p, 1080 p (FHD Portrait), 720 p (HD Portrait), 360 p (Portrait)]

Bitrate (kbit/s)

[200 to 4,000]

Frame rate (fps)

[1 to 10]

GOP length

[5 to 50]

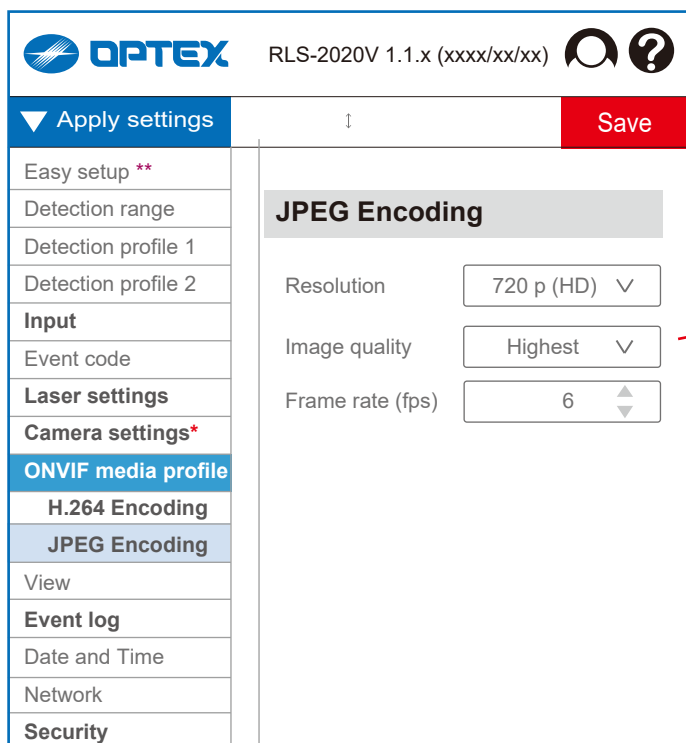

(Bold letters = advanced settings)
 .* = RLS-2020V only ** = Ver.1.1 or later

5-5-2. JPEG Encoding

Resolution

[720 p (HD), 360 p, 720 p (HD Portrait), 360 p (Portrait)]

Image quality

[Highest, High, Normal, Low, Lowest]

Frame rate (fps)

[1 to 10]

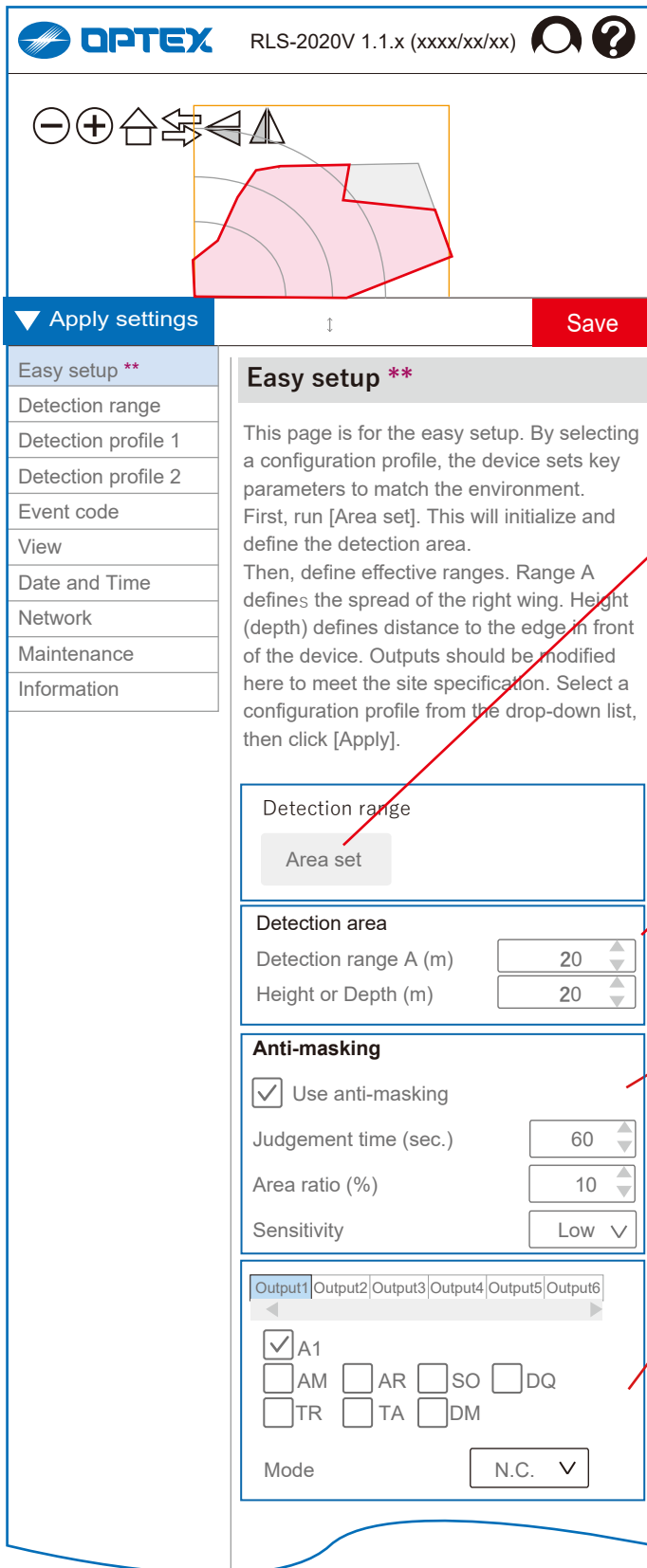

** = Ver.1.1 or later

4-1. Easy setup ** (Ver.1.1 or later)

Detection range

Area set

Start the area scanning and then setting.
Click to pop-up open the confirmation window,
and start the area scanning after OK is clicked.

These items are already set in "Initial settings", in normal process, so there is no need to set these items again. Modify the parameters only when you need to change them.

Detection area

Normal mode Expansion mode

Detection range A (m) [0 to 20] [0 to 30]

Height or Depth (m) [0 to 20] [0 to 30]

Anti-masking

Anti-masking enable

Judgement time (sec.) [1 to 600 (= 10 min.)]

Area ratio (%) [10 to 100]

Sensitivity [Low, Middle, High]

Output

Can set the each terminal individually.
[Output 1, 2, 3, 4, 5, 6]

Select events

[A1, A11, A12, A21, A22, B11, B12, B21, B22,
AM, AR, SO, DQ, TR, TA, DM]

Output when the selected event occurs.

R.E.C. (REDS CAN Event Code)

A1, A11, A12 B11, B12: Zone alarm

AM: Anti-Masking

AR: Anti-Rotation

DQ: Environmental Disqualification

DM: Device Monitoring

MO: Master Alarm

SO: Soiling

TA: Tamper Output

TR: Device Trouble

Select output mode

[N.O., N.C.]

Configuration profile

Indoor restricted access zone / human wrist ▾

Apply

Applying the configuration profile changes key parameters only. For detailed setup, go to [Detection range/Detection profile 1]. [Save] will keep the setting in memory. Perform a walktest and make modifications to parameters when necessary.

Detection range

Detection mode Outdoor ▾

Tilt direction Auto ▾

High resolution

Detection area

Offset (mm) 50

Detection

Sensitivity (msec) 150 ▲▼

Minimum target size (width)(mm) 200 ▲▼

Ignoring Area from Ground (mm) 250 ▲▼

Minimum tracking size (mm) 50 ▲▼

Detection advanced

Non-detection zone (m) 1.5 ▲▼

Environmental resistance Disable ▾

Auto area adjustment

Adjust detection area

Maximum adjusting height (m) 1 ▲▼

Small animal tolerance

View report

Configuration profile

The following profiles are available
 Indoor restricted access zone / human wrist
 Indoor limited access zone / human arm
 Indoor common access zone / human body
 Outdoor foot path / human crossing
 Outdoor fence side / human climbing

Detection range

Detection mode [Outdoor, Indoor]
 Tilt direction [Vertical, Horizontal, Auto]
 "Auto" setting allows to detect the direction in the "Area setting" and set the method automatically. Use in default "Auto" setting normally.
 High resolution [Invalid, Valid]
 Inactivate: Scan period 25 ms, 380 steps
 Activate: Scan period 50 ms, 760 steps

Detection area

Offset (mm) [0 to 1,000 (= 1 m)]

Detection

The display/setting items differ depending on the outdoor/indoor, horizontal/vertical and moving object detection/presence modes. For an explanation of each function, refer to the explanation on page 24.

Detection advanced

The display/setting items differ depending on the outdoor/indoor, horizontal/vertical and moving object detection/presence modes. For an explanation of each function, refer to the explanation on page 25 and followings.

View report

Pressing the button, a new screen will open. After entering the site information, entered data in the "Easy setup" will be displayed and a print dialog will appear.

4-2. Detection range

These items are already set in "Initial settings", in normal process, so there is no need to set these items again. Modify the parameters only when you need to change them.

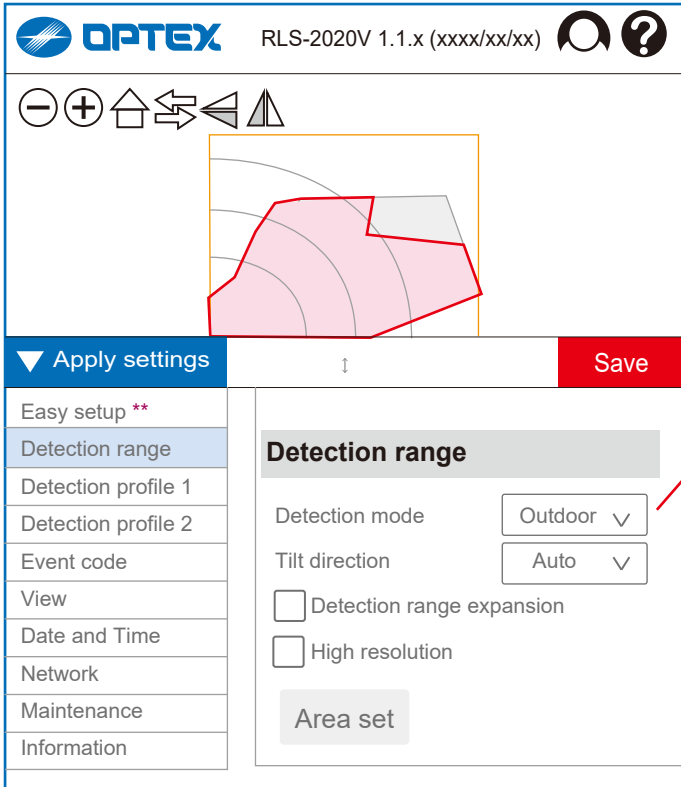

** = Ver.1.1 or later

Detection mode [Outdoor, Indoor]

Tilt direction [Vertical, Horizontal, Auto]

“Auto” setting allows automatic detection of the orientation in the "Area Setting".

Detection range expansion

Normal mode (20 m x 20 m Square)

Expansion mode (30 m x 95° Fan-shaped)

High resolution [Invalid, Valid]

Inactivate: Scan period 25 ms, 380 steps

Activate: Scan period 50 ms, 760 steps

Area set

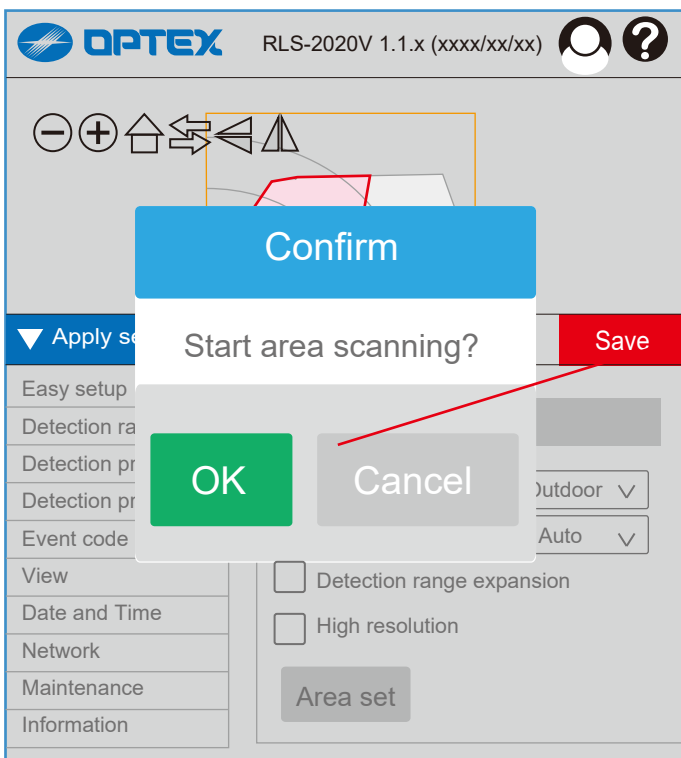

Confirmation 1

Click "OK" to start the area setting, or "cancel" it.

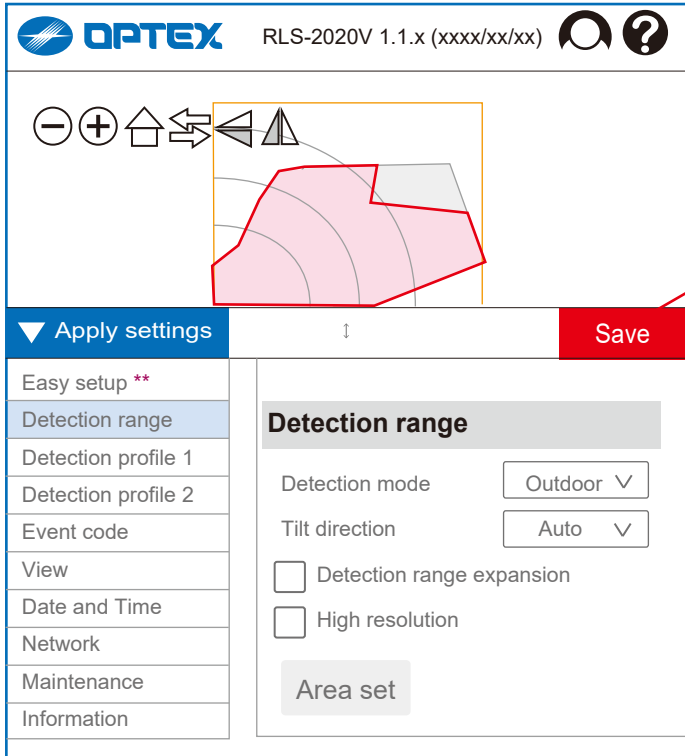

Save the settings
Click to save the detection range settings.

** = Ver.1.1 or later

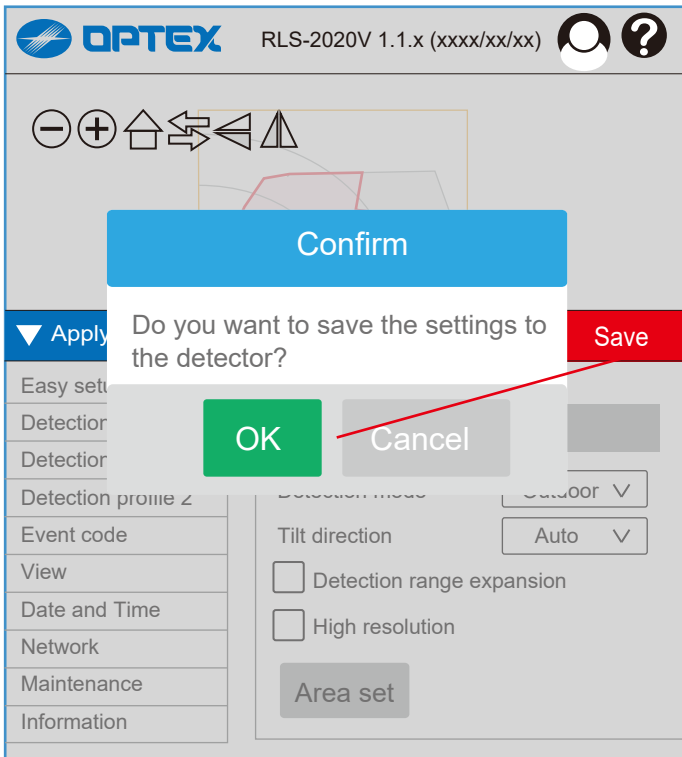

Confirmation 2
Next click the "Save" icon, second confirmation window opens.

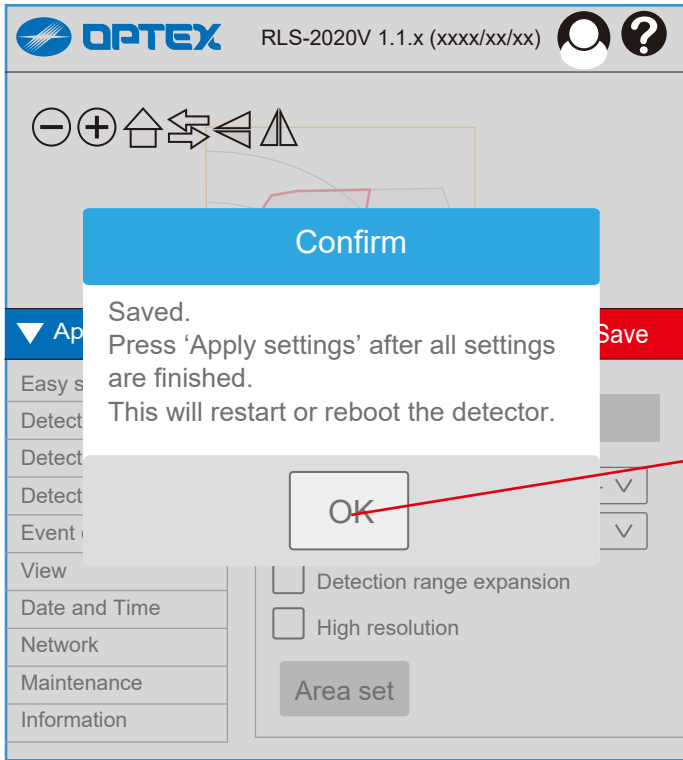

Confirmation 3

Final confirmation of the detection range settings, after saving them.

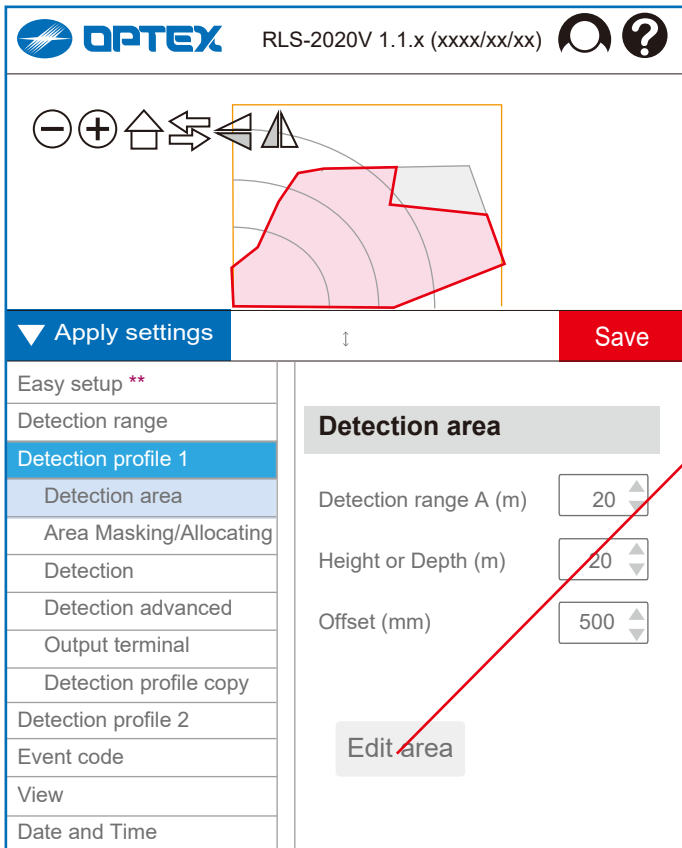

4-3. Detection profile 1

4-3-1. Detection area

	Normal	Expansion
Detection range A (m)	[0 to 20]	[0 to 30]
Height or Depth (m)	[0 to 20]	[0 to 30]
Offset (mm)	[0 to 1,000 (= 1 m)]	

Edit area

Open the separate window to edit the detection area.

Detection Range
 Detection area can be limited by "range A" and "Height or Depth". Yellow line will indicate the effective detection range after settings are completed.

Offset
 Perimeter of detection area near background can be excluded by the Offset distance. In vertical mode, obstacles on the ground or floor can generate false alarm. Also, plants and small animals can cause false alarm.

** = Ver.1.1 or later

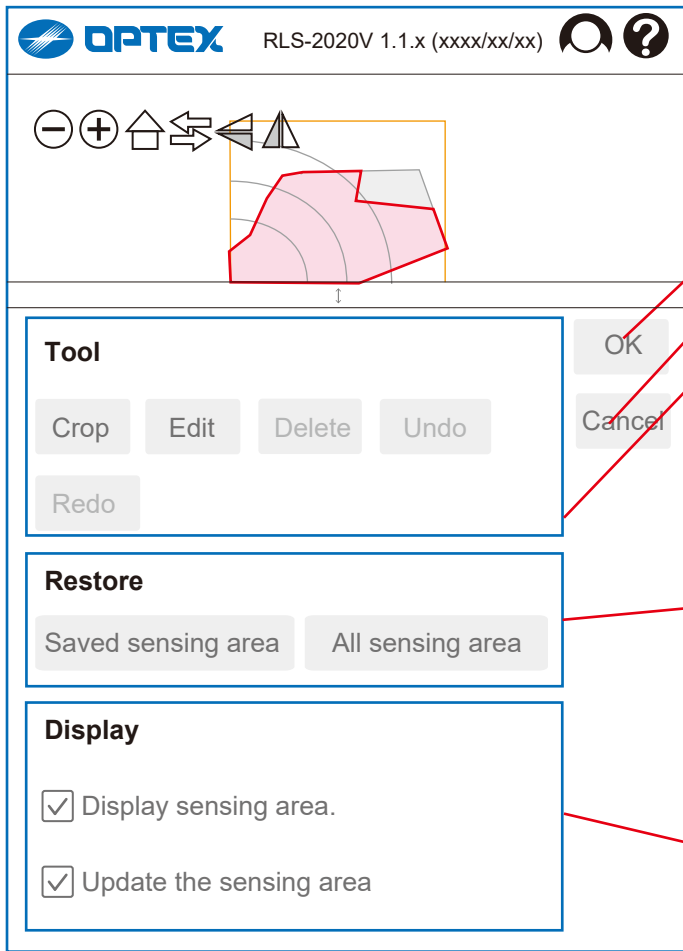

** View window can be moved by dragging, when any "tool" is not selected.*

OK: save the edited results.

Cancel: undo the edited results.

Tool

Crop: cutting the detection area partially.

Edit: adjust the shape of the cutting area.

Delete: cancel the cutting of the detection area.

Undo: return to the previous shape of the detection area.

Redo: cancel "undo" .

--> See the Example below for details.

Restore

Saved sensing area:

revert the sensing area to the saved one.

All sensing area:

setting the detection area so as to cover all sensing areas.

Display

Display the sensing area.

Update the sensing area.

Example

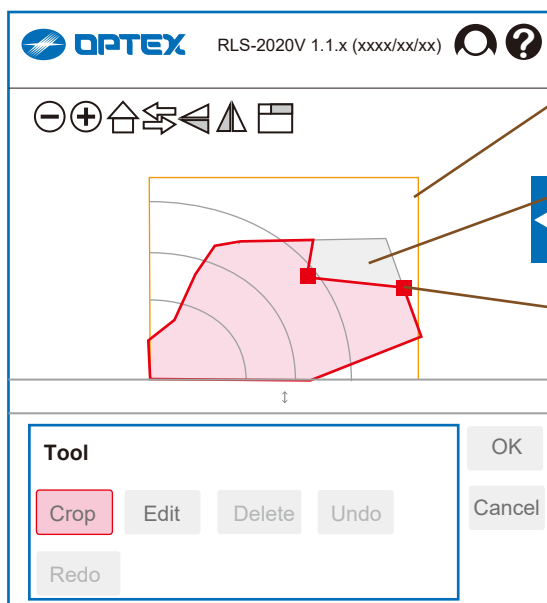

Initial scan area

The shape at the time of area setting is displayed in grey line.

Cutting by "Crop"

Anything outside of the cut area (in red) is excluded.

Adjusting by "Edit"

The shape of the cutting area can be adjusted.

4-3-2. Masking/ Allocating

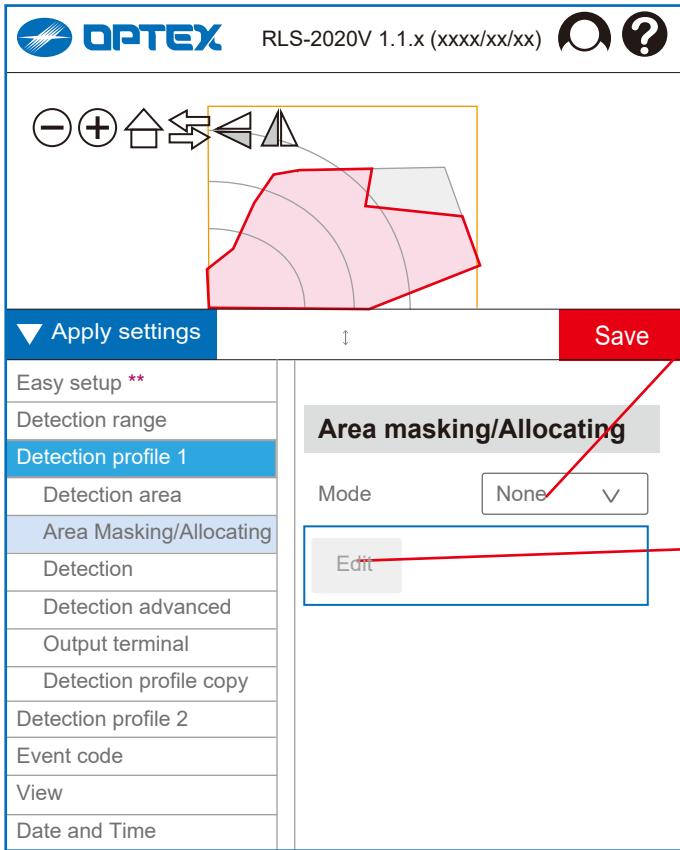

- Mode [None, Mask, Allocating]
- Mask: masking area is available to ignore some areas and reduce false alarm.
- Allocating: allocated areas are available to distinguish where objects are detected.
- Edit the masking/ allocating
- Open the separate window to edit masking/allocating.

**=Ver.1.1 or later

4-3-2-1. Masking

*** View window can be moved by dragging, when any "tool" is not selected.**

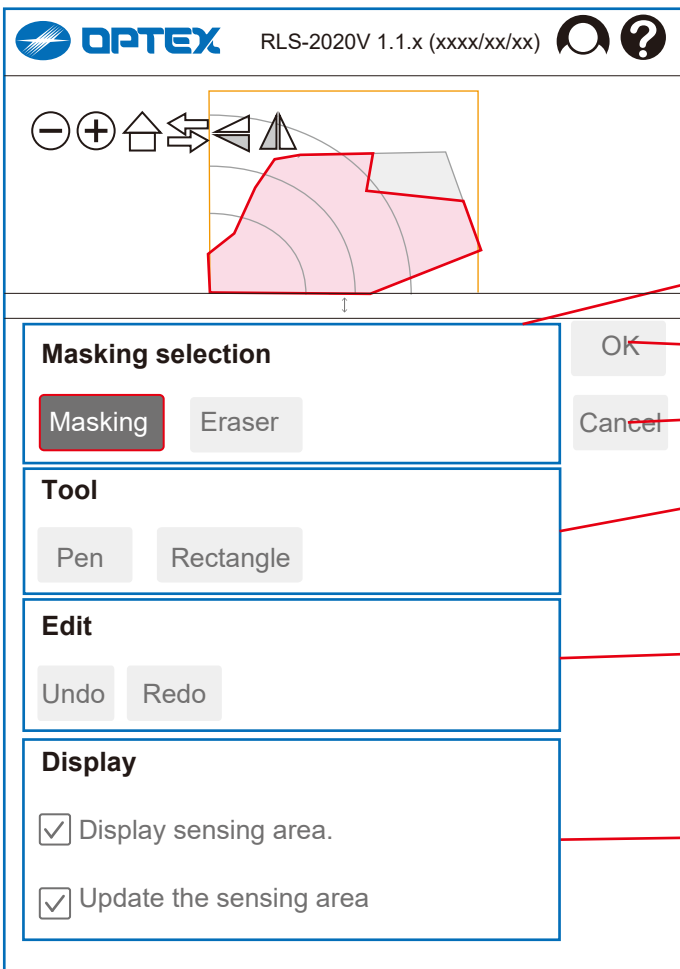

- Masking selection
- Select masking or erasing.
- Save the edited results.
- Cancel the edited results.
- Tool
- Select Pen or Rectangle.
- > See the explanation on the next page for details.**
- Edit
- Undo: return to the previous settings.
- Redo: cancel "undo" .
- Display
- Display the sensing area.
- Update the sensing area.

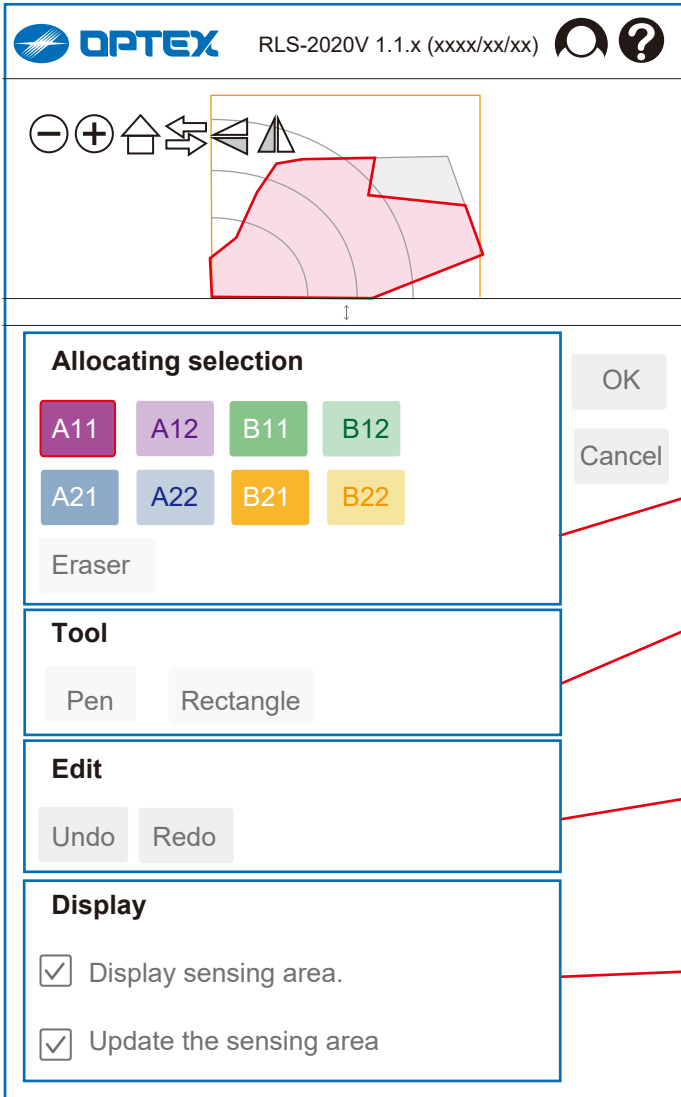

4-3-2-2. Allocating

Allocation selection

Select one to allocate.

Tool

Select Pen or Rectangle.

--> See the explanation below for details.

Edit

Undo: return to the previous settings.

Redo: cancel "undo" .

Display

Display the sensing area.

Update the sensing area.

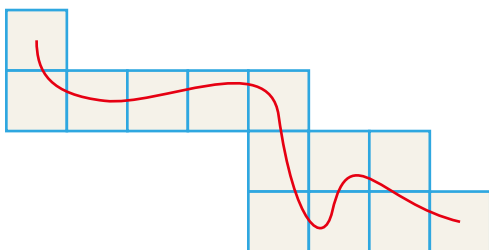

Selecting sections by "Pen" tool

Sections through which the pen passed are selected.

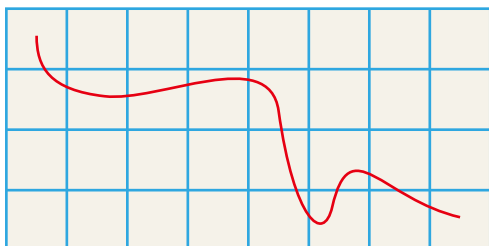

Selecting sections by "Rectangle" tool

Quadrilateral sections between the start and end points are selected.

4-3-3. Detection

Multi settings

If "Use multi detection sensitivity" is selected, each detection area can be configured independently.

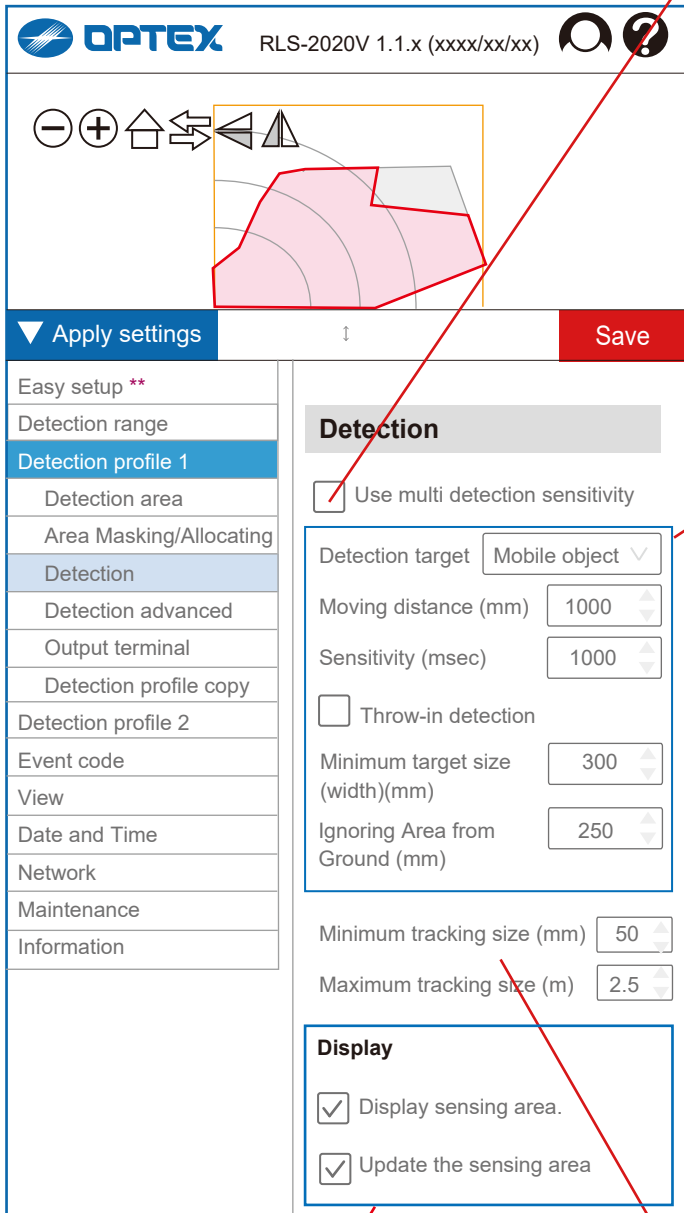

** = Ver.1.1 or later

Detection

Use multi detection sensitivity

A11 A12 B11 B12 A21 A22 B21

Detection target Mobile object

Moving distance (mm) 1000

Detection target [Mobile object, Presence]

Moving distance (mm) *Mobile object only*
[500 to 10,000 (= 0.5 to 10 m)]

The Moving distance is to avoid false alarm caused by static obstacles. If an object is detected longer than the moving distance, alarm is risen.

Sensitivity (msec.) *Presence only*
[50 to 900,000 (= 15 min.)]

The Sensitivity is to avoid false alarm caused by instantaneous event. If an object is detected longer than the Sensitivity time, alarm is raised.

Throw-in detection *Presence only*

Detects objects that pass quickly through the detection area, such as thrown objects. Since it detects instantly, the risk of false alarm increases depending on the environment.

Minimum target size (width) (mm)
[10 to 1,000 (= 1 m)]

The Size is to avoid false alarm caused by small object. If an object is smaller than Minimum Target Size, the object is ignored.

Ignoring Area from Ground (mm) *Vertical mode only*
[1 to 5,000 (= 5 m)]

Objects near to ground are ignored. Enter the height of the ignoring area.

Minimum tracking size (mm) [10 to 1,000 (= 1 m)]

If an object is smaller than Minimum Tracking Size, the object is ignored. After an object is detected, the object is tracked while the size is larger than Minimum Tracking Size.

Maximum tracking size (m) [1 to 50]

If an object is bigger than Maximum Tracking Size, the object is ignored. After an object is detected, the object is tracked while the size is smaller than Maximum Tracking Size.

Display

Display the sensing area.

Update the sensing area.

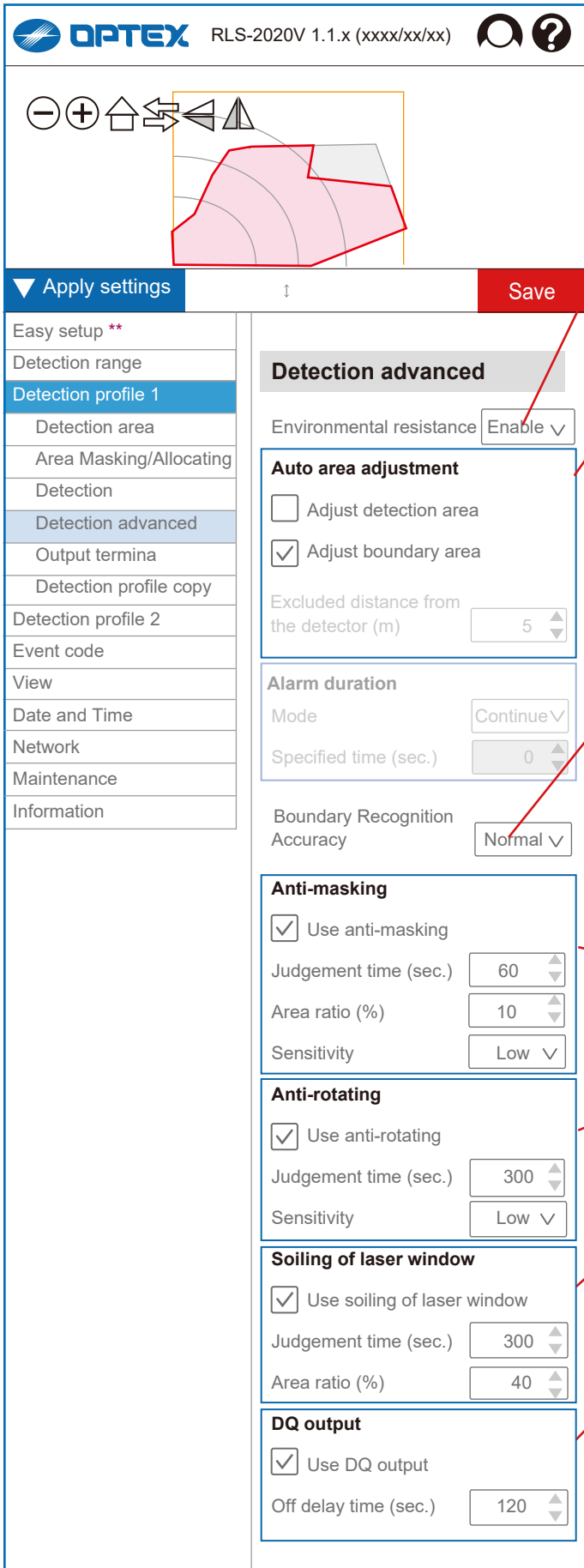

4-3-4. Detection advanced

1. Common items for Horizontal/Vertical mode

Environmental resistance *Outdoor mode only*
[Disable, Enable, Enhanced]

Disable: Response time of alarm is minimum but false alarm can increase in harsh environment such as fog or snow.

Enable: False alarm can be reduced by balanced detection ability.

Enhanced: False alarm due to fog or snow is reduced, but response time is longer and some objects may not be detected.

Auto area adjustment

REDCAN mini-Pro continues to learn background area and update background information gradually. By checking Adjust Detection Area, the detection area is adjusted proportionally to the background. (i.e. False alarm by snow can be reduced.)

Adjust detection area

When enabled, adjusts the detection area. To adjust the detection area, Adjust boundary area must be enabled.

Adjust boundary area

When enabled, adjusts the boundary area.

Boundary Recognition Accuracy [Low, Normal, High]

By changing this parameter that defines the accuracy for the recognition of the boundary (e.g. wall, floor, ground), the unit may easily detect the target which is located near the boundary.

Default value is Normal. "High" can be selected.

Higher accuracy condition, the unit can detect the target near the boundary, on the other hand, there is a possibility that it makes false alarms by noise from the surface.

Therefore it is advised to carry out a test to check its affect carefully at the actual site before operation .

Anti-masking enable

Judgement time (sec.) [1 to 600 (= 10 min.)]

Area ratio (%) [10 to 100]

Sensitivity [Low, Middle, High]

Anti-rotating enable

Judgement time (sec.) [1 to 600 (= 10 min.)]

Sensitivity [Low, Middle, High]

Soiling of laser window enable

Judgement time (sec.) [1 to 600 (= 10 min.)]

Area ratio (%) [10 to 100]

DQ (Disqualify) output enable

Off-delay timer (sec.) [1 to 600 (= 10 min.)]

Anti-Masking

Detects obstacles which mask the detector.

Anti-Rotation

Detects if the unit is rotated.

Soiling of the Window

Detects dirt is soiling detector window.

DQ (Environmental Disqualification) output

Detects harsh environment, fog, rain, or snow for example.

** = Ver.1.1 or later

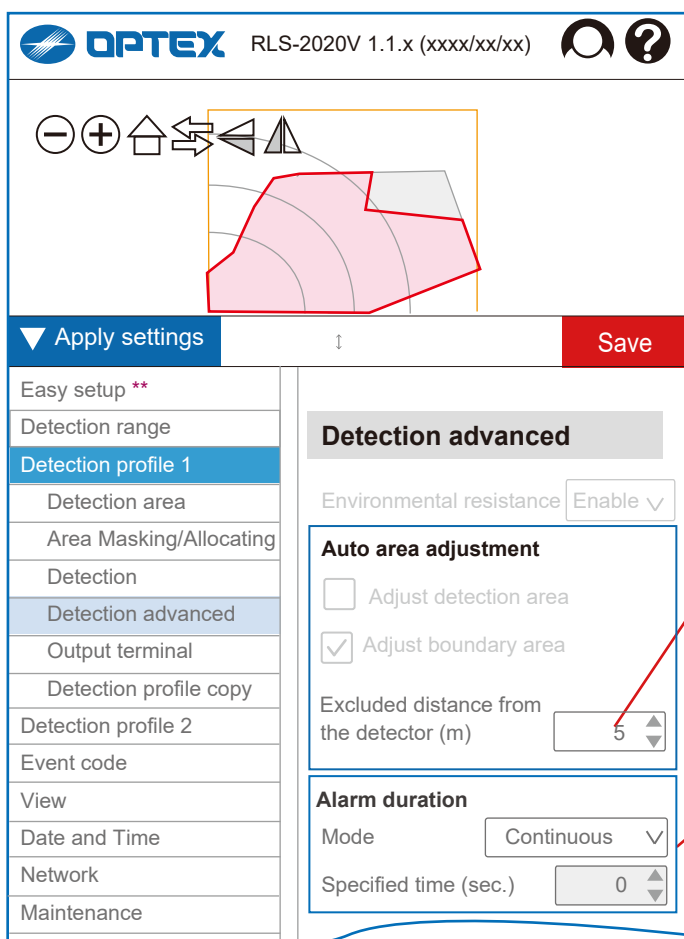

** = Ver.1.1 or later

2. Horizontal mode

Excluded distance from the detector (m)
[0 to 20 rectangle, 0 to 30 fanshape]

In horizontal mode, it follows background changes excluding closer area to the detector than the parameter value, and updates the detection area appropriately.

Alarm duration *Mobile object only*

Mode [Continuous, Preset]

Continuous:

As long as an object remains in the detection area after detection, it keeps the alarm condition.

Preset:

Even though an object remains in the detection area after detection, the alarm will be restored after the preset time.

Specified time (sec.) [1 to 30,000 (= 500 min.)]

Setting for alarm duration after detection.

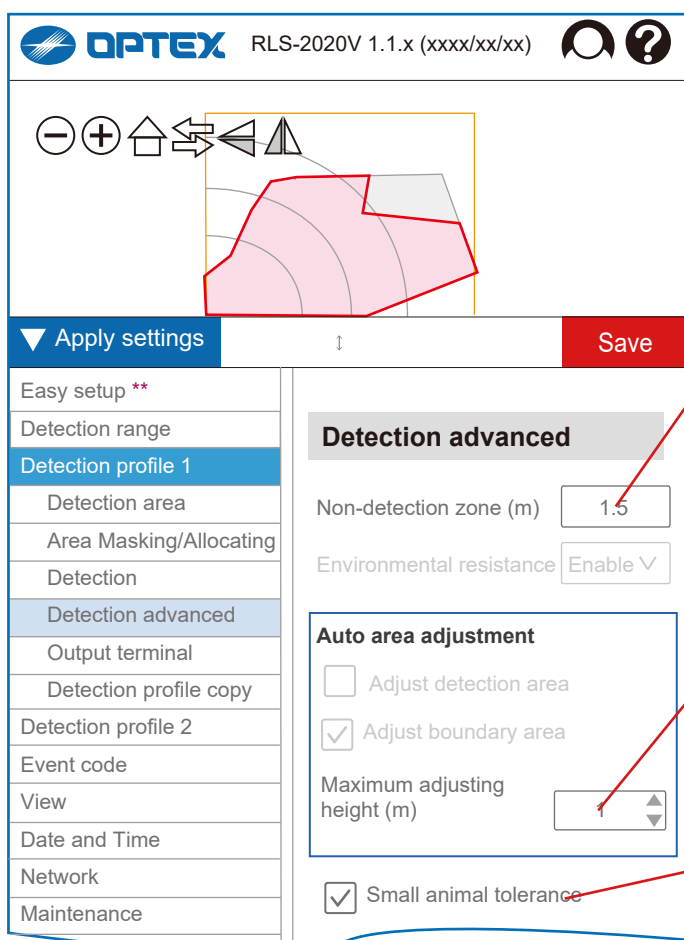

** = Ver.1.1 or later

3. Vertical mode

Non-detection zone (m)
[0 to 20 rectangle, 0 to 30 fanshape]

Objects near to ceiling are ignored.

In vertical detection area, protruding objects on the ceiling can cause false alarm. Enter the height of the ignoring area.

Maximum adjusting height (m)
[0 to 20 rectangle, 0 to 30 fanshape]

In vertical mode, the auto area adjustment can be limited using this setting. Changes under the height are learned as background.

Small animal tolerance

In vertical mode, small animals on the ground are ignored by this function.

Additional menu on Profile 1 and 2

When set the "Always show advanced settings" is enabled, following menu items appear on each Profile 1 and 2.

--> Refer to Section "4-6-4. Menu" or "5-1. Menu view".

- [1] 4-3-5. Dynamic event filtering
- [2] 4-3-7. ONVIF digital input
- [3] 4-3-8. ONVIF motion alarm
- [4] 4-3-9. HTTP notice

4-3-5. Dynamic event filtering

Use dynamic event filtering

When this function is enabled, detection area A is assigned as an "Alert zone" and detection area B is assigned as a "judgement zone", and the output is judged by the AND or NAND logic of each area. In addition, all detection areas B never create an alarm by itself alone.

Alert zone

The detection area A that can be used as an "Alert zone" is displayed. When the area filter is available, "A11", "A12" ... so on are displayed, and each area can be configured independently.

Action [None, Advance, Suppress]

None: Dynamic event filtering can not be used for this area.

Advance: Only conditions under detections in the "Judgement area", the detection in the "Alert zone" creates alarm condition. (AND logic)

Suppress: Only conditions without detection in the "Judgement area", the detection in the "Alert zone" creates alarm condition. (NAND logic)

Judgement processing [Once, Always]

Once: Judgement is executed only during the "Alert hold-off period". After the "Alert hold-off period" ends, the alarm will be output based on the judgement result.

Always: Judgement is always executed after the "Alert hold-off period" ends, the alarm will be output based on the judgement result. (Delay timer)

judgement condition

The detection area B that can be used as an "Judgement zone" is displayed. When the area filter is available, "B11", "B12" ... so on are displayed, and can be set also the input terminal as the judgement condition.

Alert hold-off period (sec.) [0 to 900 (= 15 min.)]

Set the period from the detection in the "Alert zone" to the alarm output. (Delay timer)

judgement extension time (sec.) [0 to 900 (= 15 min.)]

Set the extension time for the "judgement condition" . (OFF-delay timer)

The screenshot shows the 'Dynamic event filtering' configuration page. On the left is a navigation menu with items like 'Easy setup **', 'Detection range', 'Detection profile 1', 'Area Masking/Allocating', 'Detection', 'Detection advanced', 'Dynamic event filtering' (selected), 'Output terminal', 'ONVIF digital input', 'ONVIF motion alarm', 'HTTP notice', 'Detection profile copy', 'Detection profile 2', 'Input', 'Event code', 'Laser settings', 'Camera settings *', and 'ONVIF media profile'. The main content area has a 'Dynamic event filtering' header, a 'Use dynamic event filtering' checkbox, a dropdown menu showing 'A1', and several configuration fields: 'Action' (None), 'Judgement processing' (Once), 'Judgement condition' (Input terminal 1 and 2), 'Alert hold-off period (sec.)' (0), and 'judgement extension time (sec.)' (2). Below these is a 'Display' section with two checked checkboxes: 'Display sensing area.' and 'Update the sensing area.'

(Bold letters = advanced settings)

* = RLS-2020V only ** = Ver.1.1 or later

Display

Display the sensing area.

Update the sensing area.

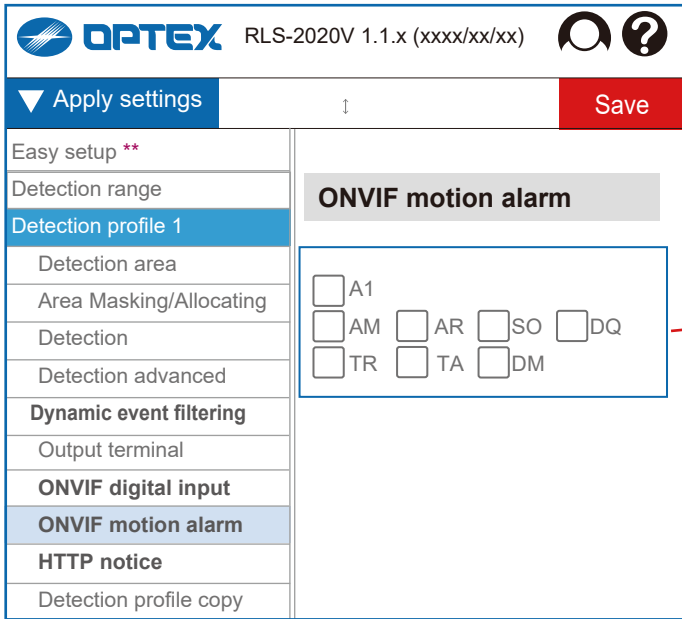

4-3-8. ONVIF motion alarm

Can set the ONVIF motion alarm responding to the select events.

Select events

[A1, A11, A12, A21, A22, B11, B12, B21, B22, AM, AR, SO, DQ, TR, TA, DM]

Respond when the selected event occurs.

-> See "4-3-6. Output terminals" for R.E.C (REDSAN event code)

(Bold letters = advanced settings)

** = Ver.1.1 or later

4-3-9. HTTP notice

A function to control external devices using HTTP based on R.E.C (REDSAN event code).

AXIS devices controlled by Virtual Inputs and Generic devices controlled by HTTP commands can be used.

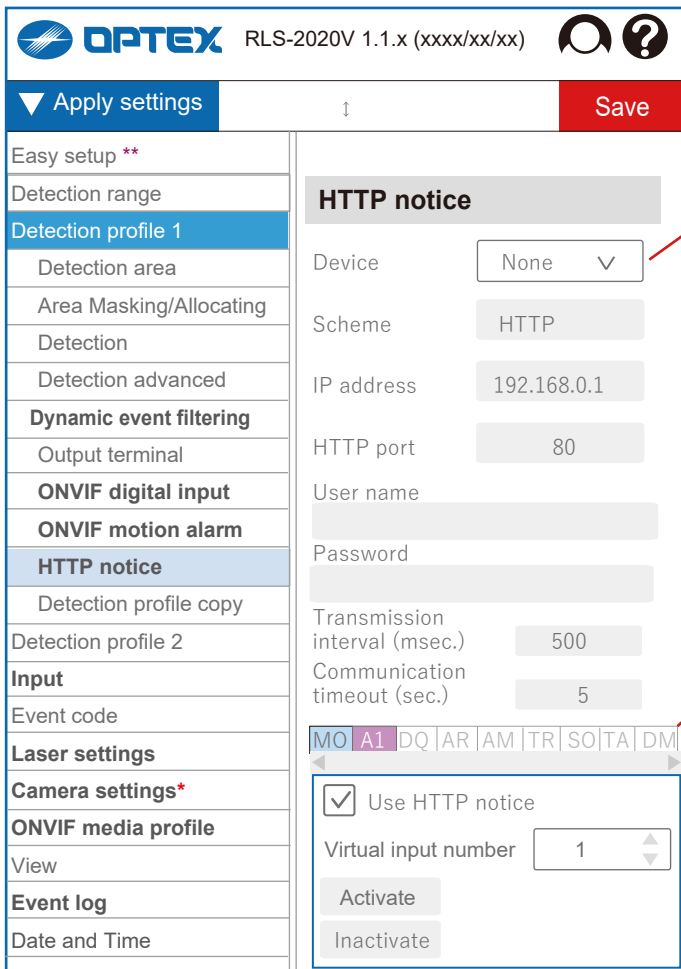

Device [None, AXIS device, Generic device, AXIS camera station]

Scheme [HTTP, HTTPS]

IP address

HTTP/HTTPS port

User name

Password

Transmission interval (msec.)

[500 to 10,000 (= 10 sec.)]

Communication timeout (sec.) [2 to 10]

Event setting

Can be set for each selected event.

Use HTTP notice

Virtual input number [1 to 32] *1

Activation URI *2

Inactivate URI *2

Triger name *3

Activate: Test output.

Inactivate: Stops test output.

Inactivate all: Stops all test outputs. *2*3

*1 = AXIS device only.

*2 = Generic device only.

*3 = AXIS camera station only.

(Bold letters = advanced settings)

.* = RLS-2020V only ** = Ver.1.1 or later

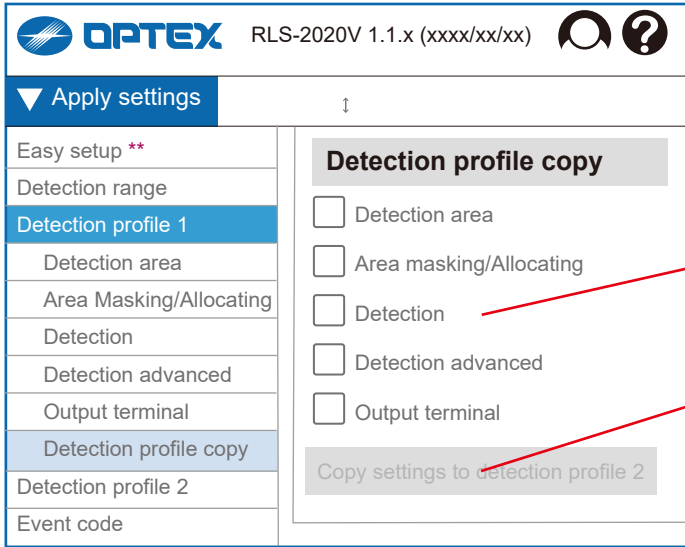

4-3-10. Detection profile copy

Copy the settings to the profile 2.

It can be adjusted individually after copying.

Select items

The selected items will be copied to the profile 2.

Copy icon

It can be pushed at least one item is selected.

** = Ver.1.1 or later

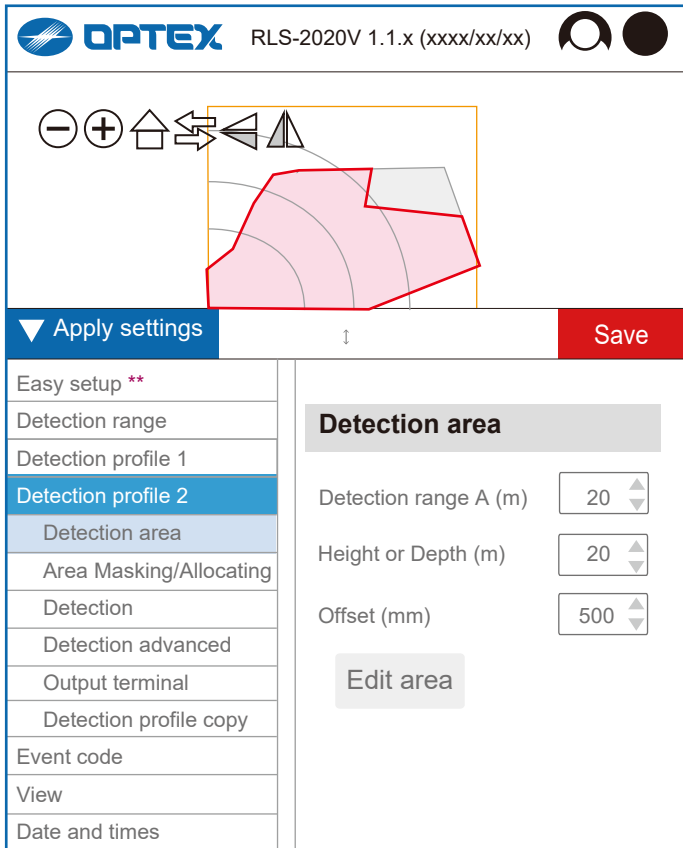

4-4. Detection profile 2

Set each item step by step just the same as detection profile 1.

Each item of profile 1 can be also copied to profile 2.

** = Ver.1.1 or later

4-5. Event code

Use event code

If unchecked, the event code will not be sent.

Select the type of the communication protocol
[UDP, Primary TCP, UDP + Primary TCP, Primary/Secondary TCP, UDP + Primary/Secondary TCP]

UDP (IPv4) settings

Scope [Broadcast, Unicast]

IP address

Port number

Number of transmission [1 to 20]

Primary/ Secondary TCP (IPv4/v6) settings

IP address

Port number

Communication timeout (ms)

[5 to 1,000 (= 1 s)]

ID settings

arbitrary detector ID enable

Detector ID [0 to 999]

Transmission

Event code transmission interval (sec.)

[1 to 3,600 (= 60 min.)]

Clear code timing (sec.) [2 to 60 (= 1 min.)]

Enable heartbeat

Heartbeat for Device Monitoring:

If it is checked, DM code is stored in R.E.C. and sent by Transmission Interval.

Send event code immediately when an alarm occurs

Remove the check mark, if you want to reduce the traffic of the event code.

-> See "4-3-6. Output terminals" for R.E.C (REDS CAN event code)

** = Ver.1.1 or later

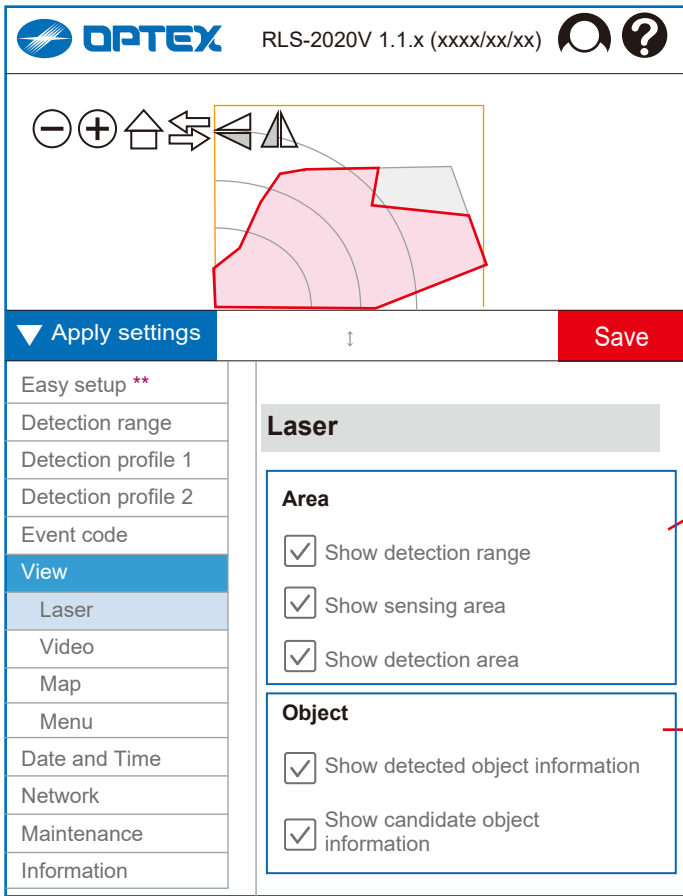

4-6. View

4-6-1. Laser

- Detection/sensing area
- Show detection range *1
- Show sensing area *2
- Show detection area *3

- Object settings
- Show detected object information
- Show candidate object information

** = Ver.1.1 or later

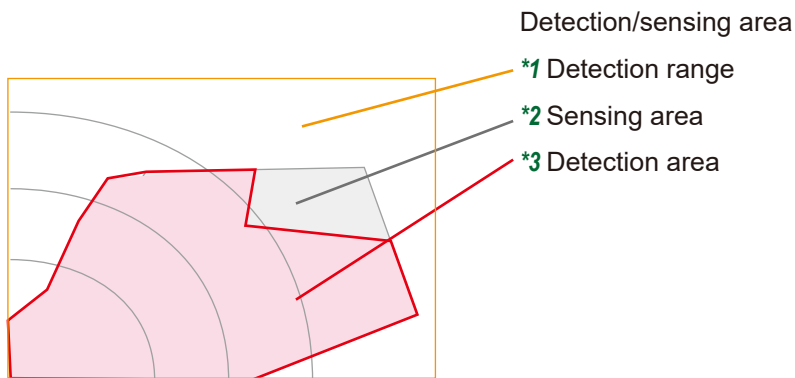

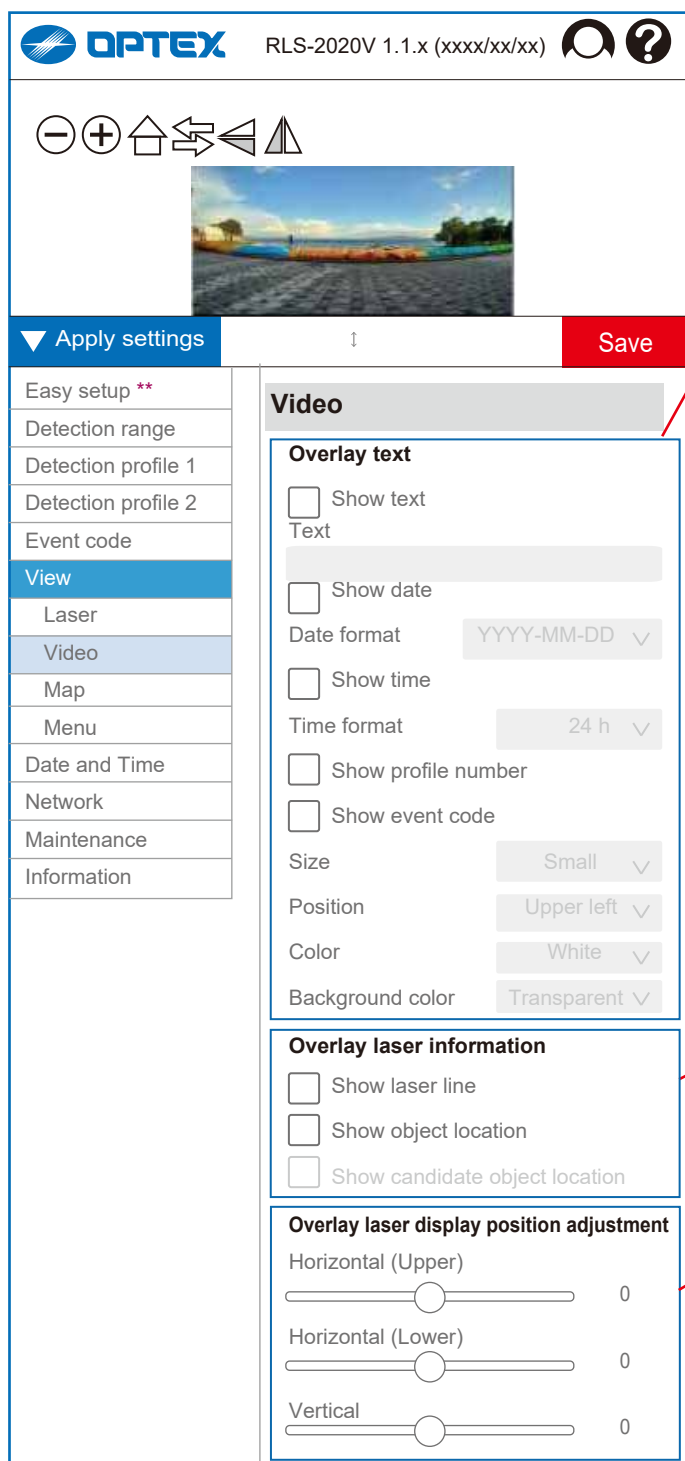

** = Ver.1.1 or later

4-6-2. Video

Overlay text

They do not appear in the images on the browser.
Only for RTSP streaming.

Show text

Text [A to Z, a to z] [0 to 9] [! " # \$ % & ' () *
+ , - . / : ; < = > ? @ [] ^ _ ` { | } ~ space]

Show date

Date format [YYYY-MM-DD, MM/DD/YYYY]

Show time

Time format [12h, 24h]

Show profile number

Show event code

Size [Small, Middle, Large]

Position [Upper right, Upper left, Lower right,
Lower left]

Color [White, Black]

Background color [White, Black, Transparent,
Semi-transparent]

Overlay laser information

Show laser line *1

Show object location *2

Show candidate object location *3

Overlay laser display position adjustment

Horizontal (Upper) [-539 to +539]

Horizontal (Lower) [-539 to +539]

Used to check the laser irradiation position with LAC-1
and adjust the position of the laser line in the horizontal
direction.

Vertical [-15 to +15]

If the object captured by the camera and the object
position are misaligned, adjust in the Vertical direction.



Overlay laser information

*1 Laser line

*2 Object location

*3 Candidate object location

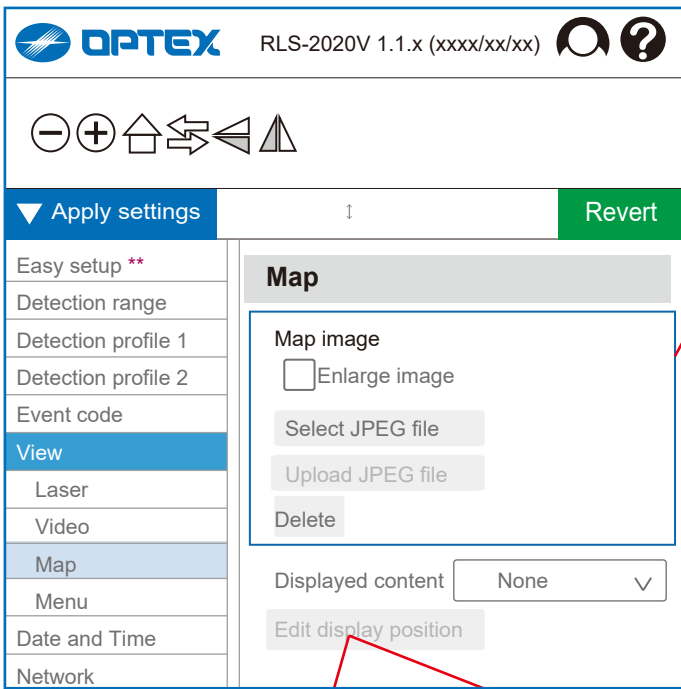

** = Ver.1.1 or later

4-6-3. Map

Map image

Image display settings for the ONVIF distribution video. JPEG files of prepared background images or bird's-eye view images are displayed instead of the real time camera images, enabling both detection area/intruding object position display and privacy protection.

Enlarge image

Select JPEG file

Upload JPEG file

Delete

Displayed contents [None, Scan area, Object position]

Edit display position

Scan area

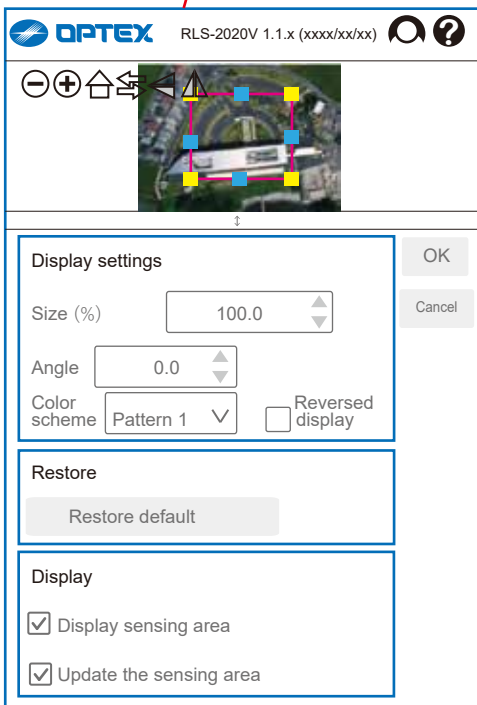

Object position

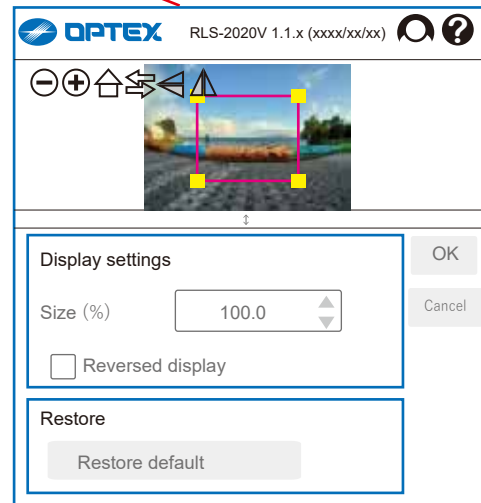

Edit display position

Role of nodes

Yellow : Resize

Light blue : Rotation

(Displayed only when the "scan area" is selected.)

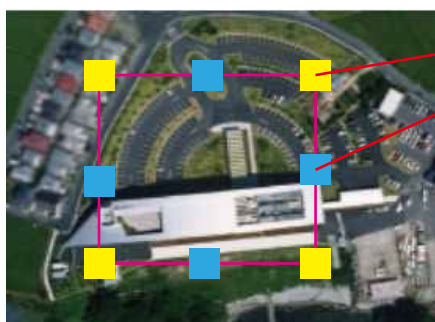

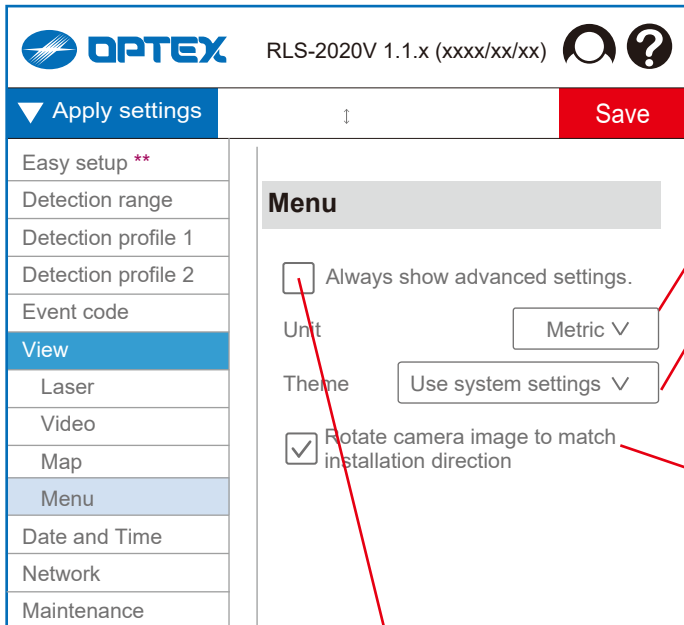

4-6-4. Menu

Unit [Metric, Feet]

Theme

[Use system settings, Light, Dark]

Use system settings: Works with the theme settings for PCs and smartphones.

Light: Displayed on the screen in light mode.

Dark: Displayed on the screen in dark mode.

Rotate camera image to match installation direction

If it is checked, the camera image will be rotated to match the installation direction. ***

The rotation direction of the camera image is determined during area scanning.

*** Web UI settings screen only

** = Ver.1.1 or later

Always show advanced settings

Always show advanced settings.



Always show advanced settings.

+

Save

+

Save

Easy setup **
Detection range
Detection profile 1
Detection profile 2
Event code
View
Date and Time
Network
Maintenance
Information

Detection profile 1
Detection area
Area Masking/Allocating
Detection
Detection advanced
Output terminal
Detection profile copy

Easy setup **
Detection range
Detection profile 1
Detection profile 2
Input
Event code
Laser settings
Camera settings *
ONVIF media profile
View
Event log
Date and Time
Network
Security
Maintenance
Information



Detection profile 1
Detection area
Area Masking/Allocating
Detection
Detection advanced
Dynamic event filtering
Output terminal
ONVIF digital input
ONVIF motion alarm
HTTP notice
Detection profile copy

= Advanced settings in "Detection profile1/2"

-> See section 4, each item

= Advanced settings -> See section 5.

.* = RLS-2020V only ** = Ver.1.1 or later

OPTEX RLS-2020V 1.1.x (xxxx/xx/xx)  

▼ Apply settings Save

Easy setup **

Detection range

Detection profile 1

Detection profile 2

Event code

View

Date and Time

Network

Maintenance

Information

Date and Time

Current time

Date 2021/01/26

Time 13: 31: 43

Time setting

Time zone

GMT Dublin, Lisbon, London, Reykja ▾

Mode Synchronize with PC ▾

Date 2021/01/26

Time 13: 31: 43

NTP

Configuration Static ▾

Network address

4-7. Date and times

Current time

Date

Time

Time settings

Time zone [GMT-12 to +14]

Mode [Synchronize with PC, Synchronize with NTP, Manual setup]

Date



Time

NTP

Configuration [Static, DHCP]

Network address

** = Ver.1.1 or later

OPTEX RLS-2020V 1.1.x (xxxx/xx/xx)  

▼ Apply settings Save

Easy setup **

Detection range

Detection profile 1

Detection profile 2

Event code

View

Date and Time

Network

TCP/IP Basic

TCP/IP advanced

SNMP

RS-485

Maintenance

Information

TCP/IP Basic

IPv4

Configuration Static ▾

IP address 192.168.0.126

Subnet mask 255.255.255.0

Default gateway 192.168.0.1

MTU 1500

IPv6

Enable DHCPv6

Current IP Address

IPv4 address 192.168.0.126/24

IPv6 Link local address fe80::21f:d1ff:fe34:44/64

IPv6 Global address 2001:ce8:132:6249:21f:d1ff:fe34:44/64

4-8. Network

4-8-1. TCP/IP Basic

IPv4

Configuration [Static, DHCP]

IP address

Subnet mask

Default gateway

MTU [1000 to 1500]

IPv6

Enable DHCPv6

Current IP Address

IPv4 address

IPv6 Link local address

IPv6 Global address

** = Ver.1.1 or later

4-8-2. TCP/IP Advanced

- DNS settings
- Configuration [Static, DHCP]
- Domain name
- Primary DNS
- Secondary DNS
- HTTP setting
- HTTP Port
- HTTPS setting
- HTTPS Port
- RTSP settings
- Enable RTSP server
- RTSP Port
- Enable RTSP authentication
- Authentication of RTSP server and ONVIF server is common.
- URI of RTSP of REDSCAN mini-Pro is [rtsp://\(IP address\)/stream/0](rtsp://(IP address)/stream/0)
- URI of HTTP tunneling of REDSCAN mini-Pro is [http://\(IP address\)/stream/0](http://(IP address)/stream/0)
- WS-Discovery setting
- Enable WS-Discovery

** = Ver.1.1 or later

4-8-3. SNMP

- SNMP v1
- Enable SNMP v1
- SNMP v2c
- Enable SNMP v2c
- SNMP v3
- Enable SNMP v3
- User name
- Security level [noAuthNoPriv, authNoPriv, authPriv]
- Authentication algorithm [MD5, SHA]
- Authentication password
- Confirm authentication password
- Private key algorithm [DES, AES]
- Private key password
- Confirm private key password

** = Ver.1.1 or later

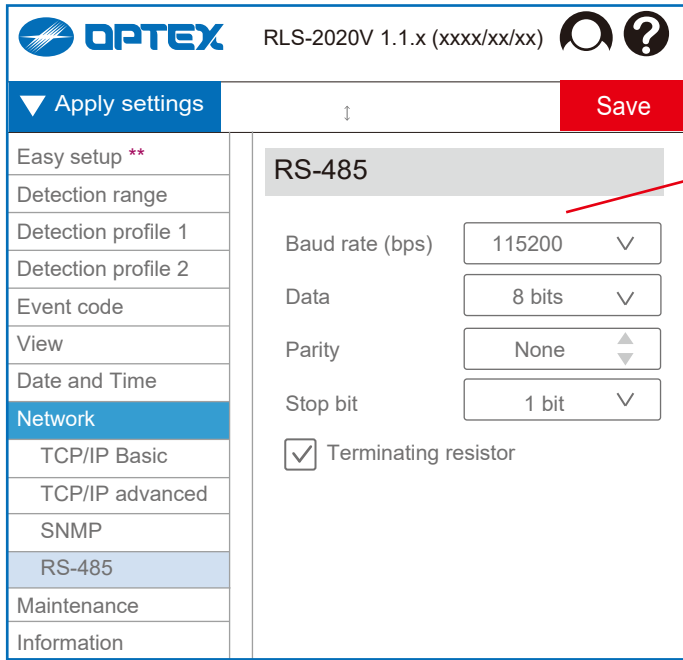

** = Ver.1.1 or later

4-8-4. RS-485

- Baud rate (bps)
[9600, 19200, 38400, 57600, 115200, 230400]
- Data (bits) [7, 8]
- Parity [None, Even, Odd]
- Stop bit (bits) [1, 2]
- Terminator [OFF, ON]

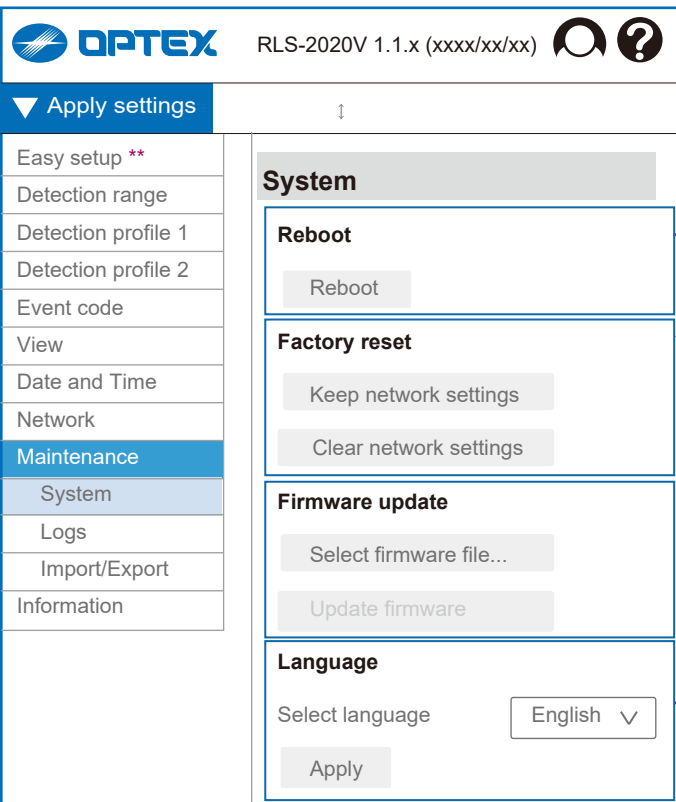

** = Ver.1.1 or later

4-9. Maintenance

4-9-1. System

- Reboot
Perform a reboot
- Factory reset
Keep network settings:
restore to the default settings except network settings
Clear network settings:
restore to the factory default with all settings
- Firmware update
Select firmware file:
open the separate window to select the file
Update firmware:
start update using the selected file
- Language
Select language
[English (Default), Français, Deutsche, Italiano, Español, Portugés Brasil, 中文, 日本語]
Apply

Firmware update:

Version up; The set parameters will be inherited even after the update.

Version down; The set parameters will **not** be inherited after the update.

All settings will **return** to factory defaults.

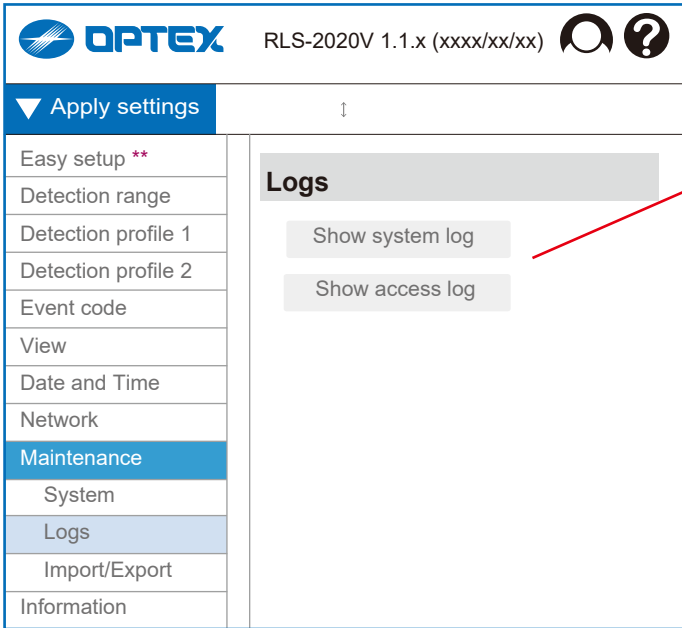

4-9-2. Logs

Show system log
Show access log

** = Ver.1.1 or later

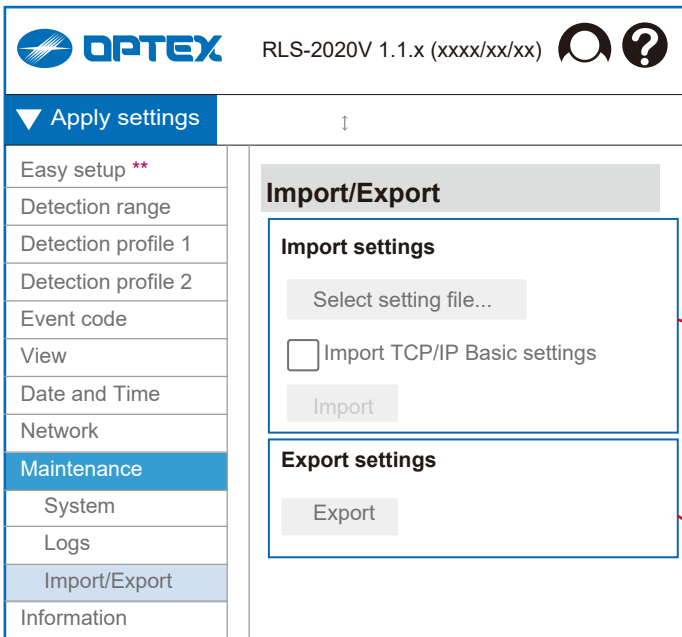

4-9-3. Import/Export

This function allows you to copy the set parameters to other devices.

For example, it is effective in the following cases.

- [1] Make the same settings for multiple devices at the same site.
- [2] Reflect all or part of past settings on different sites.
- [3] Back up the settings.

Import settings

Select setting file

Import TCP/IP Basic settings Enable

-> Refer to "4-8-1. TCP/IP Basic" about setting items.

Import starts

Export settings

Export starts

** = Ver.1.1 or later

OPTEX RLS-2020V 1.1.x (xxxx/xx/xx)

Apply settings

Easy setup **

Detection range

Detection profile 1

Detection profile 2

Event code

View

Date and Time

Network

Maintenance

Information

Product information

Installation information

Product information

Model
RLS-2020V

Serial number
XXXXXXXXXXXX

Firmware version
x.x.x (xxx/xx/xx)

MAC address
Ethernet port xx:xx:xx:xx:xx:xx
Maintenance port xx:xx:xx:xx:xx:xx

License
Show license

4-10. Information

4-10-1. Product information

Model name

Serial number

Firmware version

MAC address

License

Show the license information by selecting the icon.

** = Ver.1.1 or later

OPTEX RLS-2020V 1.1.x (xxxx/xx/xx)

Apply settings Save

Easy setup **

Detection range

Detection profile 1

Detection profile 2

Event code

View

Date and Time

Network

Maintenance

Information

Product information

Installation information

Installation information

Device
Short name
Description

Mounting
Latitude (DEG) 0
Longitude (DEG) 0
Height (m) 0
Direction (°) 0
Tilt angle (°) 0

4-10-2. Installation information

The information described here can be read by an external connection.

Show the device information

Short name

Description

Use this area freely as a memo.

Show the mounting information

Latitude (DEG)

Longitude (DEG)

Height (m)

Direction (°) [0° to 359°]

North = 0° East = 90° South = 180° West = 270°

Tilt angle (°) [-180° to +180°]

** = Ver.1.1 or later

5. Advanced Settings

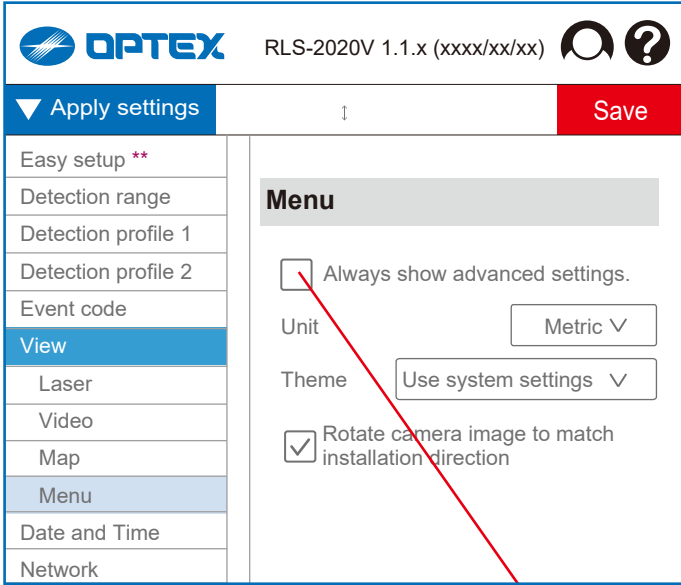

** = Ver.1.1 or later

Always show advanced settings

5. Advanced settings

5-1. Menu view

If “Always show advanced settings” is checked, several additional items will be displayed as shown.

Always show advanced settings.

+
Save

Easy setup **
Detection range
Detection profile 1
Detection profile 2
Event code
View
Date and Time
Network
Maintenance
Information

Detection profile 1
Detection area
Area Masking/Allocating
Detection
Detection advanced
Output terminal
Detection profile copy



Always show advanced settings.

+
Save

Easy setup **
Detection range
Detection profile 1
Detection profile 2
Input
Event code
Laser settings
Camera settings *
ONVIF media profile
View
Event log
Date and Time
Network
Security
Maintenance
Information

Detection profile 1
Detection area
Area Masking/Allocating
Detection
Detection advanced
Dynamic event filtering
Output terminal
ONVIF digital input
ONVIF motion alarm
HTTP notice
Detection profile copy

= Advanced settings in “Detection profile1/2”

-> See section 4, each item

= Advanced settings

* = RLS-2020V only ** = Ver.1.1 or later

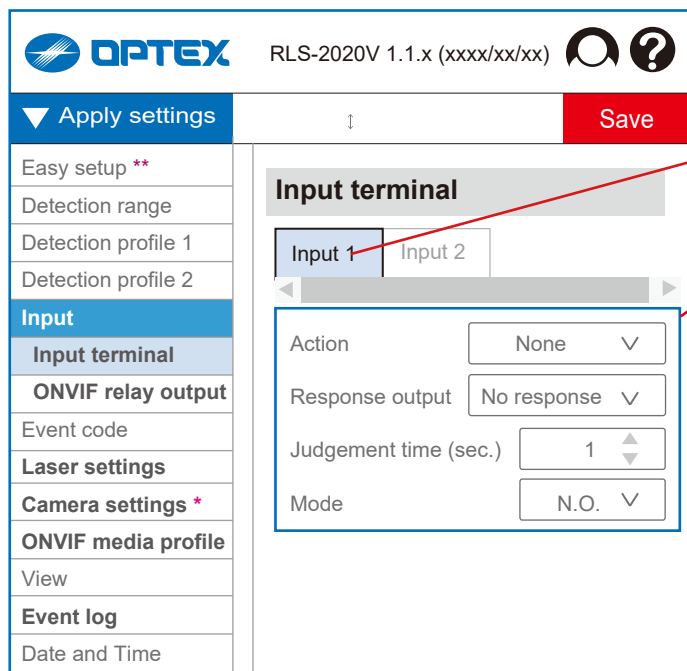

(Bold letters = advanced settings)
 .* = RLS-2020V only ** = Ver.1.1 or later

5-2. Input

5-2-1. Input terminal

Select the terminal for settings.
 [Input 1, 2]

Action
 [None, Detection profile switching, Area set, LEDs turn on, Detector check]

(1) Duplicate settings cannot be made for input 1/2 of the input terminal and RO#1/2 of the ONVIF relay output.

(2) No response is returned during trouble output (AM/AR/SO/TR) or Disqualified environment output (DQ) with "Detector check" setting.

Response output [No response, Output 1, 2, 3, 4, 5, 6]

Judgement time [0 to 10]

Mode [N.O., N.C.]

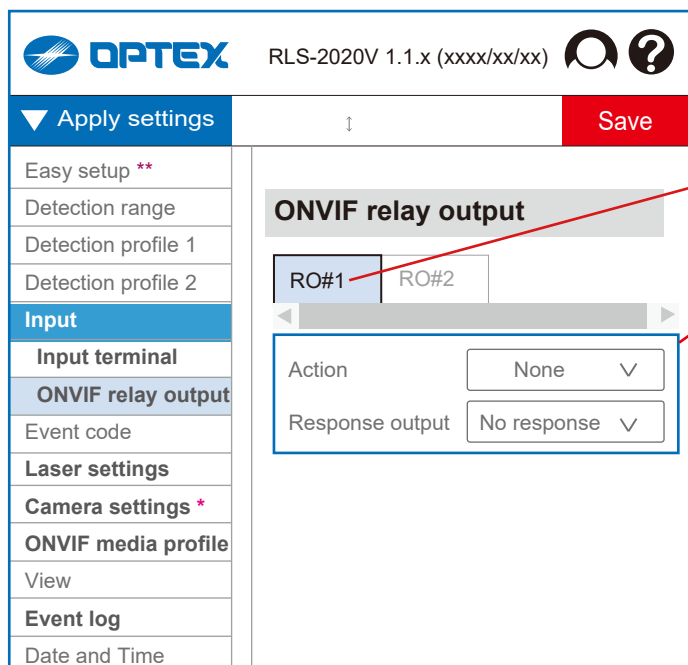

(Bold letters = advanced settings)
 .* = RLS-2020V only ** = Ver.1.1 or later

5-2-2. ONVIF relay output

Select the relay output for settings.
 [RO#1, 2]

Action
 [None, Detection profile switching, Area set, LEDs turn on, Detector check]

(1) Duplicate settings cannot be made for input 1/2 of the input terminal and RO#1/2 of the ONVIF relay output.

(2) No response is returned during trouble output (AM/AR/SO/TR) or Disqualified environment output (DQ) with "Detector check" setting.

Response output

[No response, ONVIF digital input 1, 2, 3, 4, 5, 6]

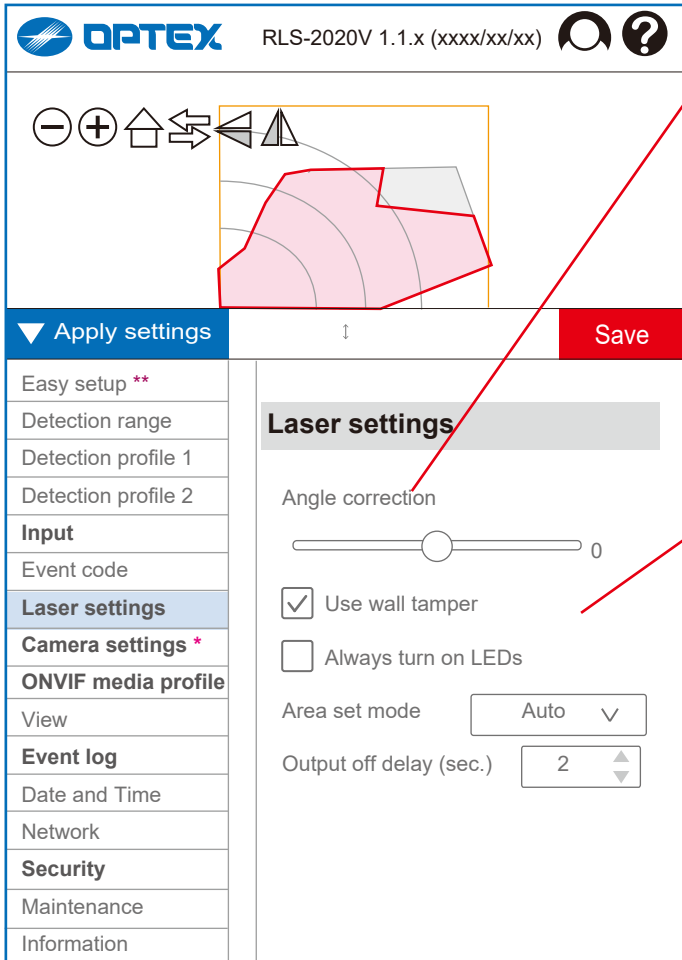

(Bold letters = advanced settings)

. * = RLS-2020V only ** = Ver.1.1 or later

5-3. Laser settings

Angle correction

Normal resolution [-2.25° to +2.5°]

High resolution [-2.375° to +2.5°]

The angle of the detection area is corrected in the software using this setting.

Use wall tamper

Turn it off when the wall tamper switch may not be pressed properly, for example mounting on a pole.

Always turn on LEDs

Area set mode

[Auto, Indoor option, Outdoor option]

In most situations leave as default "Auto", because the area set is optimized according to the Indoor/Outdoor mode. Select 2 type of options, only if "Auto" can not work properly.

Output off delay (sec.)

[0.1 to 60 (= 1 min.)]

OPTEX RLS-2020V 1.1.x (xxxx/xx/xx)

Apply settings Revert

- Easy setup **
- Detection range
- Detection profile 1
- Detection profile 2
- Input**
- Event code
- Laser settings**
- Camera settings ***
 - Image adjustment**
 - Privacy mask
 - Day/Night
 - Miscellaneous
- ONVIF media profile**
- View
- Event log**
- Date and Time
- Network
- Security**
- Maintenance
- Information

Image adjustment

Image

Brightness [0 to 100]

Contrast [0 to 255]

Sharpness [0 to 255]

Saturation [0 to 255]

Wide dynamic range

Use wide dynamic range

Flicker correction

Power line frequency [50 Hz]

5-4. Camera settings * (RLS-2020V only)
5-4-1. Image adjustment

Image

- Brightness [0 to 100]
- Contrast [0 to 255]
- Sharpness [0 to 255]
- Saturation [0 to 255]

Wide dynamic range

Dynamic range is the difference in brightness between the darkest and brightest parts of an image. When it is turned on, it is corrected so that the difference in brightness is reduced, and overexposure and underexposure are less likely to occur. It is recommended to turn it on under conditions where there is a large difference in brightness.

Flicker correction [50 Hz, 60 Hz]

It should be same as the power frequency.

(Bold letters = advanced settings)
.* = RLS-2020V only ** = Ver.1.1 or later

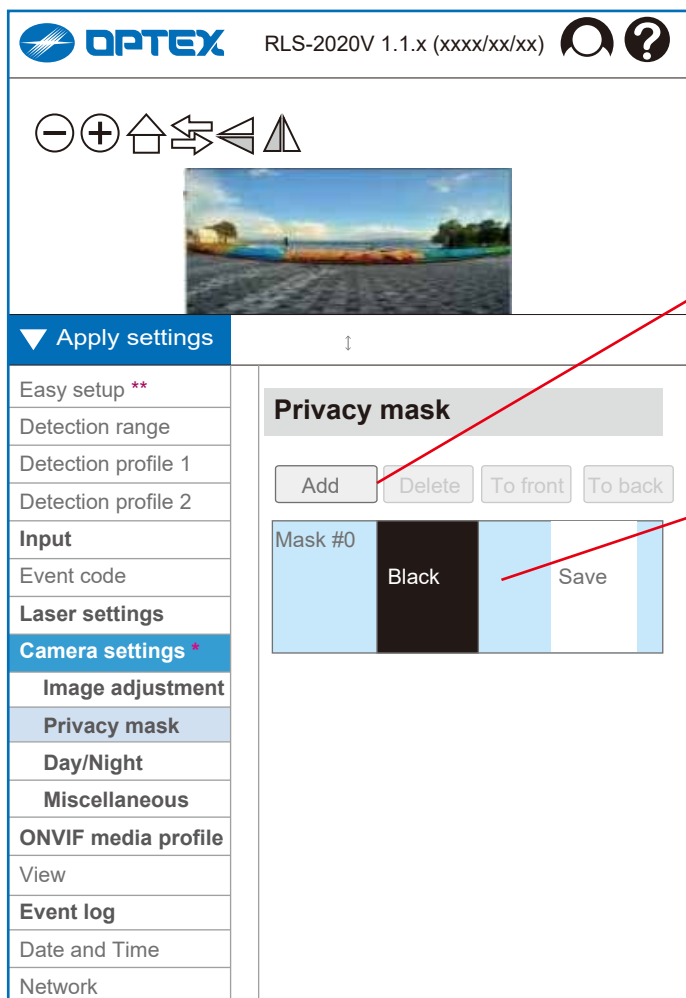

(Bold letters = advanced settings)

. * = RLS-2020V only ** = Ver.1.1 or later

5-4-2. Privacy mask

If you need to maintain privacy such as nearby facilities or people, you can use the privacy mask function to mask the specified area of the image.

Masking configuration

Add: to add a masking area for the camera images

Delete: to delete a masking area of the camera images

To front: Move the selected privacy mask forward.

To back: Move the selected privacy mask back.

Mask # [0 to 7]

Color [Black, White, Gray, Red, Blue, Green,



Cyan, Yellow, Mosaic]



Save:

To save the masking configuration. Moving to other menu item without pressing "Save", the masking settings will be restored.

Revert:

After confirming the settings by pressing "Save", the "Revert" icon will appear, allowing you to return to the settings before editing.

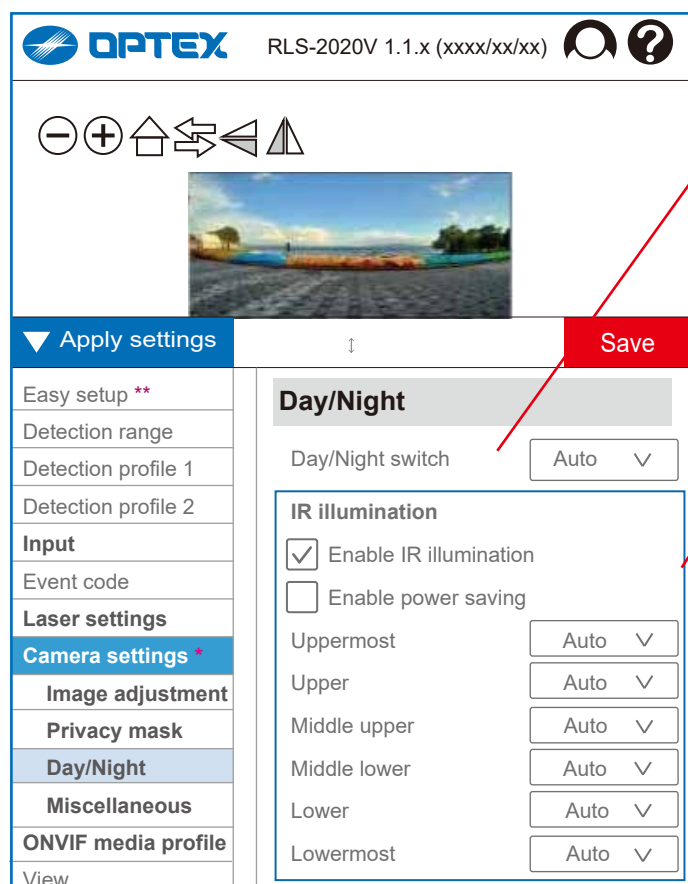

(Bold letters = advanced settings)

.* = RLS-2020V only ** = Ver.1.1 or later

5-4-3. Day/Night

Day/Night switch [Auto, Night, Day]

Auto: Switching automatically according to the ambient illuminance.

Night: It is fixed to a monochrome image so that it can record even in low light.

Day: It is fixed to a color image regardless of the ambient illuminance.

IR illumination

Enable IR illumination

Enable power saving

Reduces power consumption by reducing IR LED output when no object is detected.

Uppermost, Upper, Middle upper, Middle lower, Lower, Lowermost

[Auto, OFF, Level 1 to 5]

Auto: Adjust automatically according to the size of the scan area.

OFF: IR illumination is not activated.

Level 1 to 5: IR illumination is activated with each level.

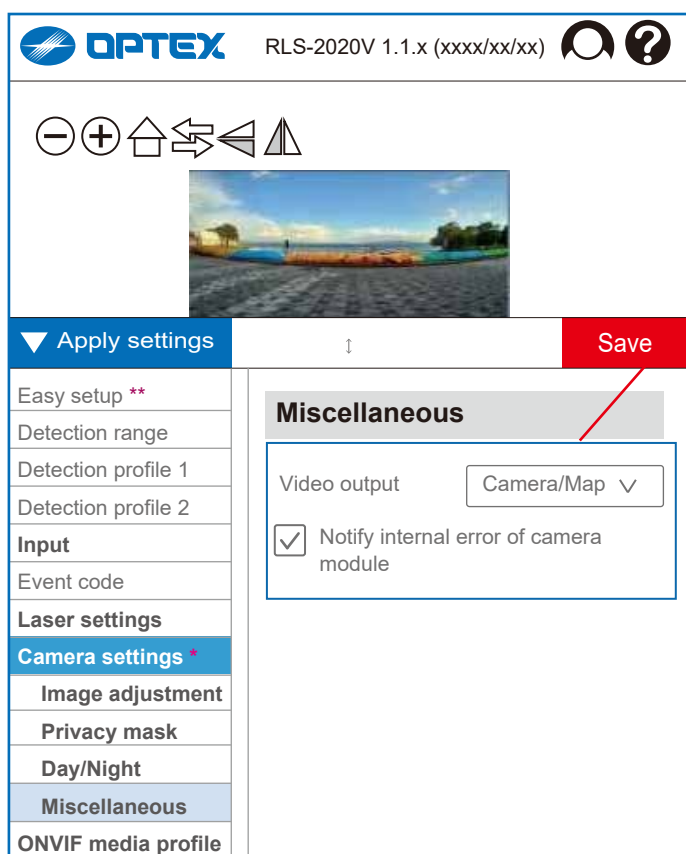

(Bold letters = advanced settings)

.* = RLS-2020V only ** = Ver.1.1 or later

5-4-4. Miscellaneous

Video output

[Camera/Map, All black, Mosaic]

Camera/Map: Camera/Map images without any processing

All black: Black images. Settings on "Camera - Privacy mask" and "View - Video" are ignored.

Mosaic: Images with mosaic. Settings on "Camera - Privacy mask" are ignored.

Notify internal error of camera module

If you set it to **enable**, the TR signal is output when an internal error occurs.

If you do **not** want to report a camera error as the TR signal, **uncheck** it.

ONVIF menu on Advanced settings

--> Refer to Section "3. ONVIF settings"

OPTEX RLS-2020V 1.1.x (xxxx/xx/xx)	
Apply settings	Save
Easy setup **	<h3>H.264 Encoding</h3> <p>Resolution: 720 p (HD) ▾</p> <p>Bitrate (kbit/s): 1000 ▲ ▾</p> <p>Frame rate (fps): 6 ▲ ▾</p> <p>GOP length: 12 ▲ ▾</p>
Detection range	
Detection profile 1	
Detection profile 2	
Input	
Event code	
Laser settings	
Camera settings *	
ONVIF media profile	
H.264 Encoding	
JPEG Encoding	
View	
Event log	
Date and Time	
Network	
Security	

(Bold letters = advanced settings)

* = RLS-2020V only ** = Ver.1.1 or later

5-5. ONVIF media profile

5-5-1. H.264 Encoding

Resolution

[1080 p (FHD), 720 p (HD), 360 p,
1080 p (FHD Portait), 720 p (HD Portait), 360 p (Portait)]
Bitrate (kbit/s) [200 to 4,000]
Frame rate (fps) [1 to 10]
GOP length [5 to 50]

OPTEX RLS-2020V 1.1.x (xxxx/xx/xx)	
Apply settings	Save
Easy setup **	<h3>JPEG Encoding</h3> <p>Resolution: 720 p (HD) ▾</p> <p>Image quality: Highest ▾</p> <p>Frame rate (fps): 6 ▲ ▾</p>
Detection range	
Detection profile 1	
Detection profile 2	
Input	
Event code	
Laser settings	
Camera settings *	
ONVIF media profile	
H.264 Encoding	
JPEG Encoding	
View	
Event log	
Date and Time	
Network	
Security	

(Bold letters = advanced settings)

* = RLS-2020V only ** = Ver.1.1 or later

5-5-2. JPEG Encoding

Resolution

[720 p (HD), 360 p, 720 p (HD Portait), 360 p (Portait)]
Image quality [Highest, High, Normal, Low, Lowest]
Frame rate (fps) [1 to 10]

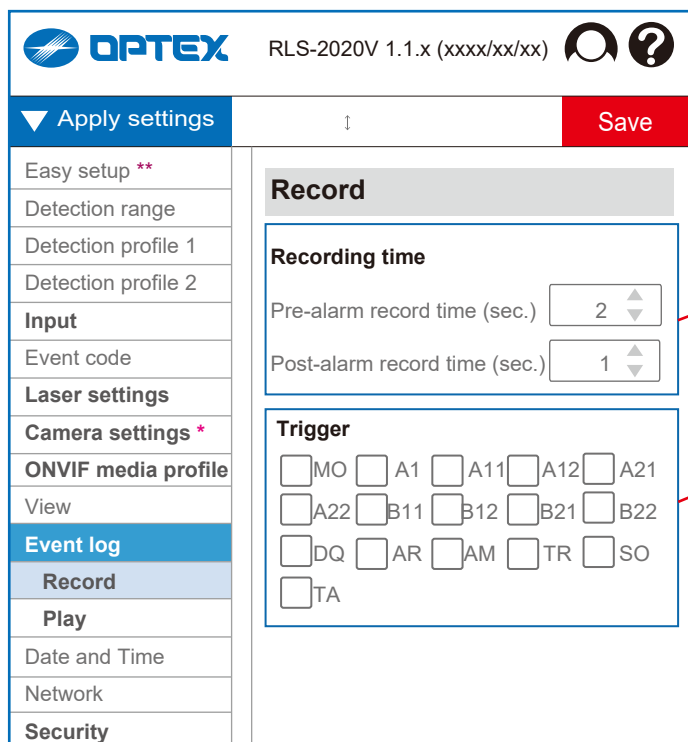

5-6. Event log

5-6-1. Record

You can save the camera image by using the set R.E.C. (**REDESCAN Event Code**. See list below) as a trigger.

You can set the Pre/Post recording time and the trigger to start recording.

You can save up to 500 logs.

Recording time

Pre-alarm record time (sec.) [2 to 5]

Post-alarm record time (sec.) [1 to 10]

Trigger

[MO, A1, A11, A12, A21, A22, B11, B12, B21, B22, DQ, AR, AM, TR, SO, TA]

R.E.C. (REDESCAN Event Code)

A1, A11, A12, B11, B12: Zone alarm

AM: Anti-Masking

AR: Anti-Rotation

DQ: Environmental Disqualification

DM: Device Monitoring

MO: Master Alarm

SO: Soiling

TA: Tamper Output

TR: Device Trouble

(Bold letters = advanced settings)

. * = RLS-2020V only ** = Ver.1.1 or later

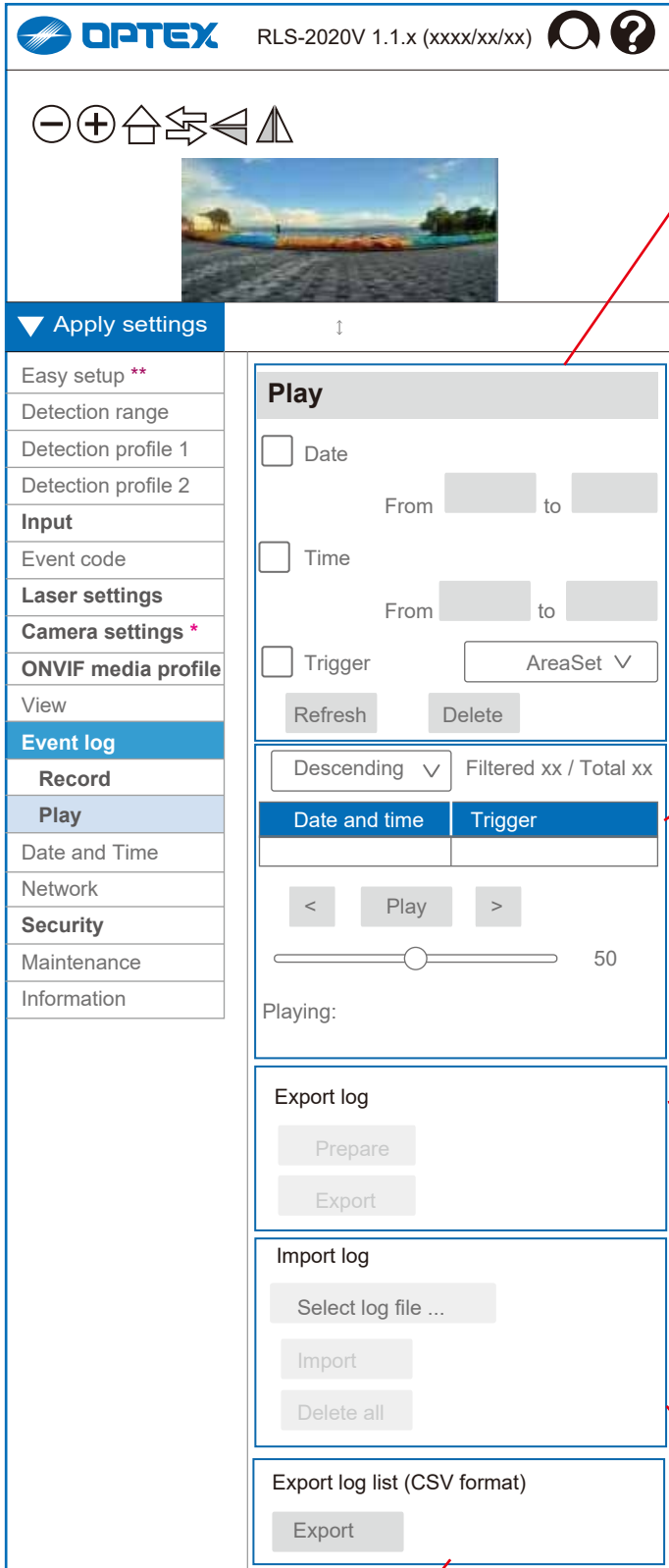

5-6-2. Play

Play the recorded images.

Play search

Date

Date from [YYYY/MM/DD] to [YYYY/MM/DD]

Time

Time from [HH:MM:SS] to [HH:MM:SS]

Trigger

[Area set, Manual,

MO, A1, A11, A12, A21, A22, B11, B12, B21, B22, DQ, AR, AM, TR, SO, TA]

Area set; Log when area set is performed

Manual; Log when recording starts

-> See "5-6-1. Record" for R.E.C (REDSCAN event code)

Refresh

Delete

List display of search results

Display order [Descending, Ascending]

Number of results: Filtered xx / Total xx

Result list view

< Play >

Playing status

Export log

Up to 5 files can be exported at the same time.

If the quantity is exceeded, an alert will be displayed when pressing the export icon.

Prepare

While preparing the event log, HTTP tunneling video distribution and WebApi acceptance will be temporarily suspended.

Export

Import log

When logs are imported, only the imported logs are displayed in the list.

(Indicated as "Displaying imported logs")

If all the imported logs are deleted, logs in the sensor are displayed.

Select log file

Import

Delete all

(Bold letters = advanced settings)

.* = RLS-2020V only ** = Ver.1.1 or later

Export log list (CSV format)

All log list are exported in CSV format.

Export

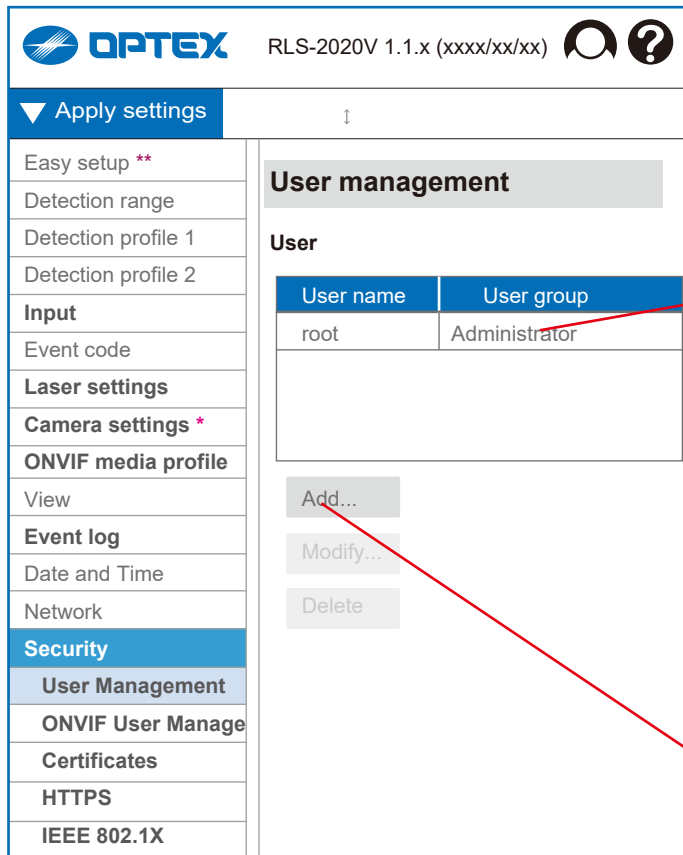

(Bold letters = advanced settings)

.* = RLS-2020V only ** = Ver.1.1 or later

5-7. Security

5-7-1. User Management

You can edit the user information to log in the system.
The maximum number of registered users is 8.

User list

Add a new user

Modify the selected user

Delete the selected user

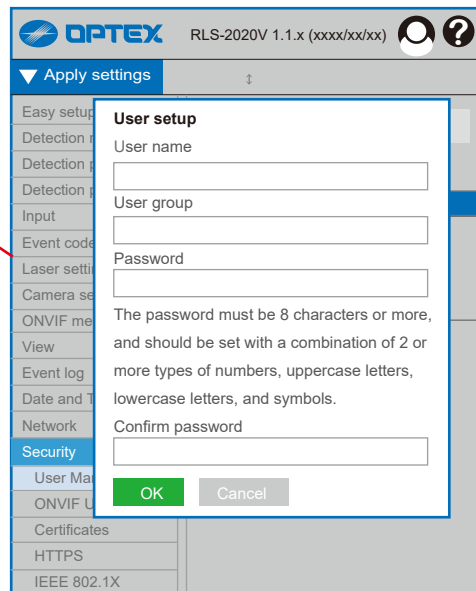

User setup

User name

User group [Administrator, Operator, Viewer]

Administrator can change **all** parameter settings.

Operator can change parameters for **display only**.

Viewer is **not permitted** to change any parameter.

Password

The password must be 8 characters or more,
and should be set with a combination of 2 or
more types of numbers, uppercase letters,
lowercase letters, and symbols.

Confirm password

OK

Cancel

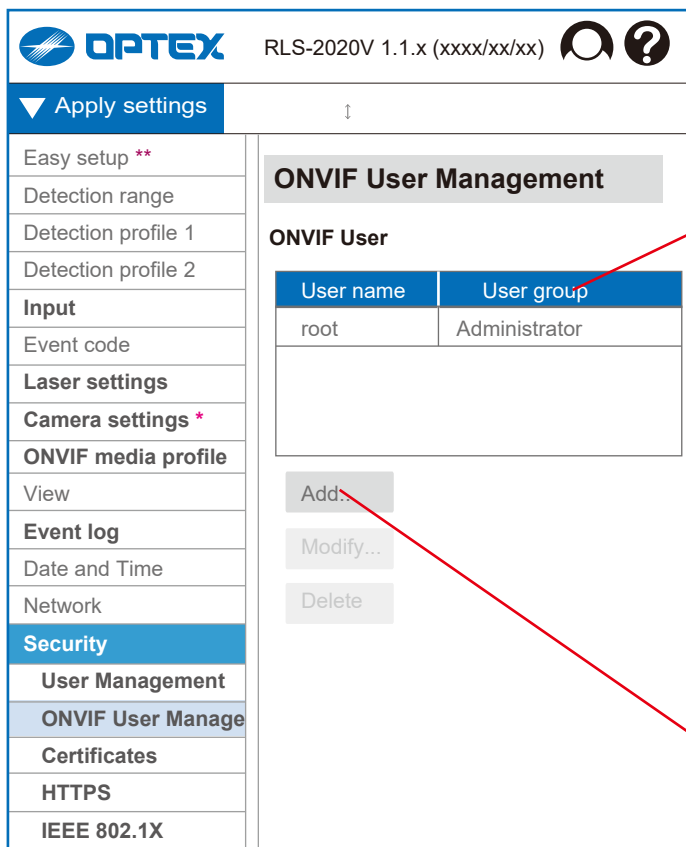

(Bold letters = advanced settings)

. * = RLS-2020V only ** = Ver.1.1 or later

5-7-2. ONVIF User Management

- User list
- Add a new user
- Modify the selected user
- Delete the selected user

This is the first item that needs to be set when using ONVIF.

The maximum number of registered users is 8.

See **Chapter 3** for details.

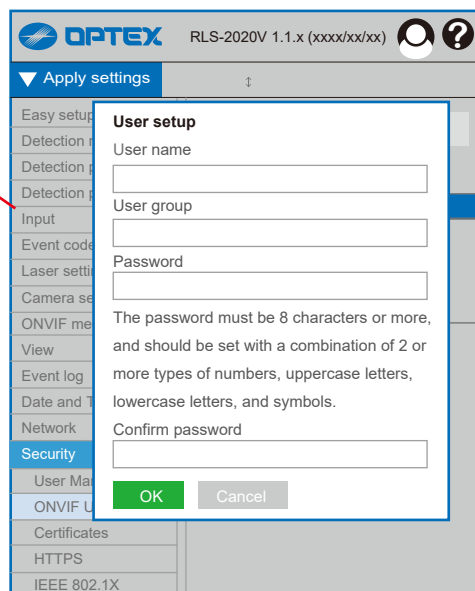

User setup

User name

User group

Select user group that is defined by ONVIF.

Password

The password must be 8 characters or more, and should be set with a combination of 2 or more types of numbers, uppercase letters, lowercase letters, and symbols.

Confirm password

OK

Cancel

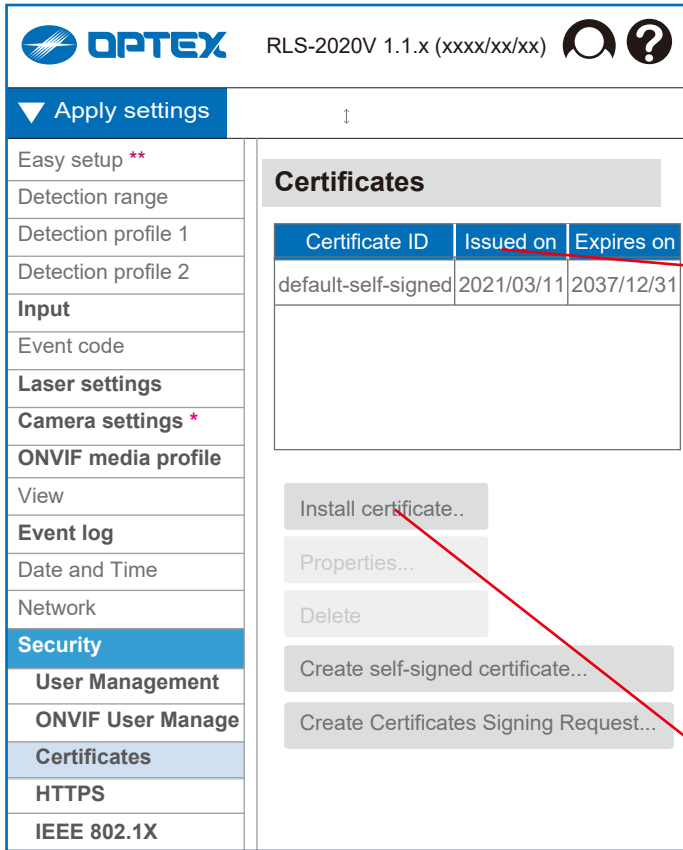

(Bold letters = advanced settings)
 .* = RLS-2020V only ** = Ver.1.1 or later

5-7-3. Certificates

Create/install a certificate required for server communication in HTTPS and IEEE 802.1X.

The maximum number of registered certificates is 10.

- Certificate ID list
- Install a certificate ID
- Properties
- Delete the current ID
- Create self-signed certificate ID
- Create Certificate Signing Request

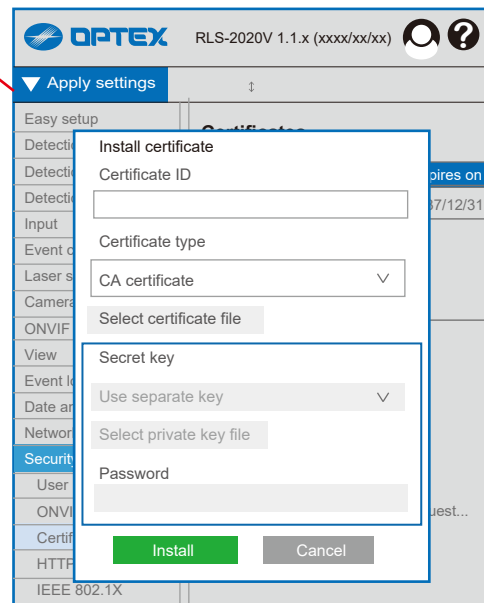

- Install certificate
- Certificate ID
- Certificate type
- [CA certificate, Certificate from signing request, Certificate and private key]
- Select certificate file
- Secret key
- [Use separate key, PKCS#12]
- Select private key file
- Password
- Install
- Cancel

5-7-4. HTTPS

Connection method [HTTP, HTTPS, HTTP & HTTPS]
 Server certificate [None, default-self-signed (- 20xx/xx/xx)]
 Choices are added when the certificate is created.
 TLS support
 [1.0 or higher, 1.1 or higher, 1.2 or higher, 1.3 only]

(Bold letters = advanced settings)

.* = RLS-2020V only ** = Ver.1.1 or later

5-7-5. IEEE 802.1X

Enable IEEE 802.1X
 EAP type [EAP-TLS, PEAP-MSCHAPv2]
 User name
 Password
 CA certificate
 Add the certificate to be used in "5-7-3. Certificates".
 Client certificate
 Add the certificate to be used in "5-7-3. Certificates".

(Bold letters = advanced settings)

.* = RLS-2020V only ** = Ver.1.1 or later



OPTEX CO., LTD. (JAPAN)
www.optex.net

OPTEX INC./AMERICAS HQ (U.S.)
www.optexamerica.com

OPTEX SECURITY SAS (France)
www.optex-europe.com/fr

OPTEX KOREA CO.,LTD. (Korea)
www.optexkorea.com

OPTEX (EUROPE) LTD./EMEA HQ (U.K.)
www.optex-europe.com

OPTEX SECURITY Sp.z o.o. (Poland)
www.optex-europe.com/pl

**OPTEX (DONGGUAN) CO.,LTD.
SHANGHAI OFFICE (China)**
www.optexchina.com

**OPTEX SECURITY B.V.
(The Netherlands)**
www.optex-europe.com/nl

**OPTEX PINNACLE INDIA,
PVT., LTD. (India)**
www.optexpinnacle.com

OPTEX (Thailand) CO., LTD. (Thailand)
www.optex.co.th

Copyright (C) 2024 OPTEX CO.,LTD.